

SARAY® | SK54

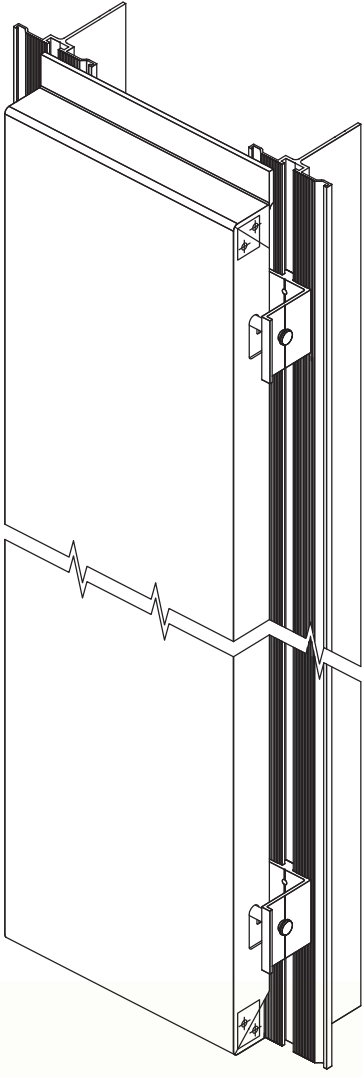

KOMPOZİT PANEL CEPHE KAPLAMA SİSTEMİ

SK54

KOMPOZİT PANEL CEPHE KAPLAMA SİSTEM

FİHRİST ve MALZEME TANIMLARI











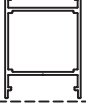

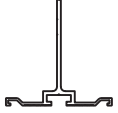

SK54

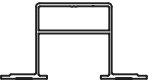
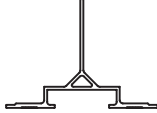
Composite Panel Structural System

İndeks & Description

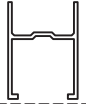
- Profiller
- Profiles

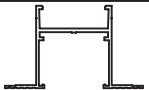
Kompozit Panel Cephe Kaplama Sistemi











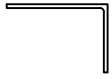

PROFİL RESMİ PROFILE PICTURE	PROFİL NO PROFILE NO	PROFİLİN İSMİ PROFILE NAME	AĞIRLIK WEIGHT (kg/m)	Jxx (cm ⁴)	Jyy (cm ⁴)
	11221	H Taşıyıcı Profili H Mullion Profile	1,310	20,33	20,14
	11235	Kitleme Profili Locking Profile	0,960	---	---
	11236	Askı Profili Hook Profile	0,475	---	---
	11257	Kitleme Profili Locking Profile	0,330	---	---
	8598	T Taşıyıcı Profili T Mullion Profile	0,910	16,00	7,01
	8599	Kitleme Profili Locking Profile	1,160	---	---
	8707	Derz Profili Finishing Profile	0,215	---	---
	10234	U Taşıyıcı Profili U Mullion Profile	1,335	17,09	30,12
	10293	T Taşıyıcı Profili T Mullion Profile	1,245	15,75	24,88
	10235	Askı Profili Hook Profile	0,625	---	---
	10236	Askı Profili Hook Profile	0,655	---	---
	10237	Başlangıç Profili Hook Profile	0,620	---	---
	5182	H Taşıyıcı Profili H Mullion Profile	1,230	---	---
	839	U Askı Profili U Hook Profile	1,110	---	---
	7168	H Taşıyıcı Profili H Mullion Profile	1,170	---	---
	10332	Bağlantı Profili Connection Profile	0,315	---	---
	10333	Kapak Profili Finishing Profile	0,135	---	---

Uyarı: Profil ağırlıklarımız teorik olup; teslim anındaki tartımız geçerlidir.
Warning: the weights of profile is theoretical, weighting at the time of delivery are valid.

* İşaretti kalıp minimum 300 kg üretilir.
* Minimum order quantity: 300 kg

Kompozit Panel Cephe Kaplama Sistemi

- Profiller
- Profiles

PROFİL RESMİ PROFILE PICTURE	PROFİL NO PROFILE NO	PROFİLİN İSMİ PROFILE NAME	AĞIRLIK WEIGHT (kg/m)	Jxx (cm ⁴)	Jyy (cm ⁴)
	504	Dolu Çubuk Profili Ø8 Full Profile Pipe Ø8	0,140	----	----
	3452	Kompozit Panel Ek Yeri Profili Joint Profile for Composite Panel	0,245	----	----
	3454	Kompozit Panel Bitiş Profili Finishing Profile for Composite Panel	0,205	----	----
	3958	Kompozit Panel F Profili F Profile for Composite Panel	0,320	----	----
	3453	Ek Yeri Profili Joint Profile	0,230	----	----
	4747	L Braket Profili 54x80 mm L Bracket Profile (anchorage) 54x80 mm	1,075	----	----
	4748	L Braket Profili 54x120 mm L Bracket Profile (anchorage) 54x120 mm	1,400	----	----
	4749	L Braket Profili 54x160 mm L Bracket Profile (anchorage) 54x160 mm	1,725	----	----
	9980	L Ankraj Profili 75x180 mm L Anchorage Profile 75x180 mm	4,215	----	----
	9981	L Ankraj Profili 75x150 mm L Anchorage Profile 75x150 mm	3,725	----	----
	9982	L Ankraj Profili 75x100 mm L Anchorage Profile 75x100 mm	2,880	----	----
	9983	Ankraj Profili Anchorage Profile	0,475	----	----
	19812	Kompozit Panel Ek Yeri Profili Joint Profile for Composite Panel	0,255	----	----
	19813	Kompozit Panel Ek Yeri Profili Joint Profile for Composite Panel	0,245	----	----

Uyarı: Profil ağırlıklarımız teorik olup; teslim anındaki tartımız geçerlidir.
Warning: the weights of profile is theoretical, weighting at the time of delivery are valid.

* İşaretili kalıp minimum 300 kg üretilir.
* Minimum order quantity: 300 kg

SK54







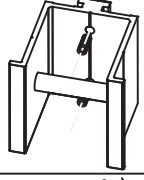
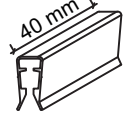
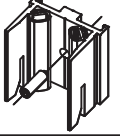
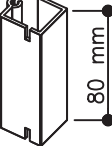
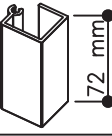

**KOMPOZİT PANEL CEPHE KAPLAMA SİSTEM
AKSESUAR FİHRİST ve MALZEME TANIMLARI**

SK54

**Composite Panel Structural System
Accessories Indeks & Description**

- Aksesuarlar
- Accessories

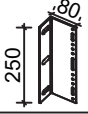
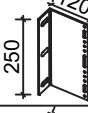
Kompozit Panel Cephe Kaplama Sistemi

RESİM	PARÇA NO	MALZEME	AÇIKLAMA	PAKET
	SC-129	EPDM	Baskı Fiteli Gasket	225 m/koli
 Die: 8599	SC-510	Alüminyum	Anahtar geçme askı elemanı "8598 nolu profille kullanılır." Hook Part	50 TK/PK
 40 mm	SC-516	PVC	Pvc Klips PVC Clips	50 Ad/Pk
 Die: 11235	SC-517	Alüminyum	Anahtar geçme askı elemanı "11 221 nolu profille kullanılır." Hook Part	50 Ad/Pk
 80 mm Die: 11236	SC-518		Askı Elemanı "11 235 nolu profille kullanılır." Hook Part	50 Ad/Pk
 72 mm Die: 11236	SC-519		Askı Elemanı "11 235 nolu profille kullanılır." Hook Part	Profil olarak satılır.
 80 Die: 4747	SC-526-80	Alüminyum	L Ara Braket 80/80 L Bracket (anchorage) 80/80	İstenilen Miktarda
 80 Die: 4748	SC-527-80		L Ara Braket 120/80 L Bracket (anchorage) 120/80	
 80 Die: 4749	SC-528-80		L Ara Braket 160/80 L Bracket (anchorage) 160/80	
 150 Die: 4747	SC-526-150		L Ana Braket 80/150 L Bracket (anchorage)80/150	
 150 Die: 4748	SC-527-150		L Ana Braket 120/150 L Bracket (anchorage) 120/150	
 150 Die: 4749	SC-528-150		L Ana Braket 160/150 L Bracket (anchorage) 160/150	
 250 Die: 4747	SC-526-250		L Ana Braket 80/250 L Bracket (anchorage) 80/250	
 250 Die: 4748	SC-527-250		L Ana Braket 120/250 L Bracket (anchorage) 120/250	
 250 Die: 4749	SC-528-250		L Ana Braket 160/250 L Bracket (anchorage)160/250	

SK54
KOMPOZİT PANEL CEPHE KAPLAMA SİSTEMİ
I:İ PROFİL KESİTLERİ
SK54
Composite Panel Structural System
Full Scale Sections

- Profiller
- Profiles

Kompozit Panel Cephe Kaplama Sistemi

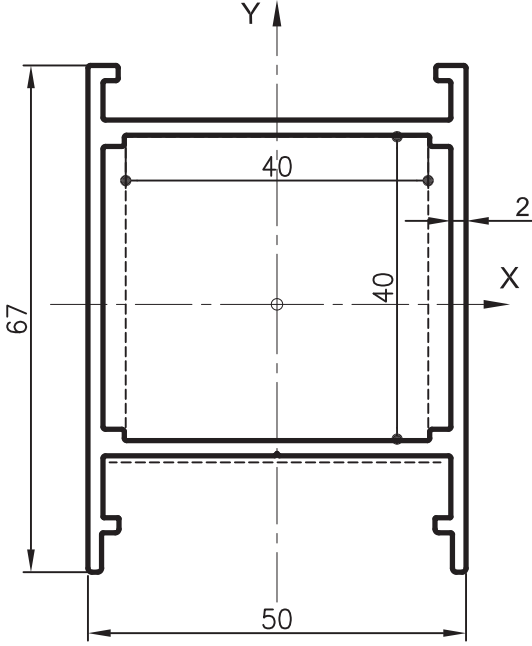

No : 11 221

Taşıyıcı H Profili $J_x=20.33 \text{ cm}^4$
1,310 kg/m $J_y=20.14 \text{ cm}^4$

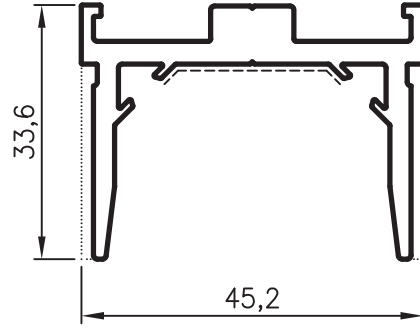

No : 11 235

Kitleme Profili
0,960 kg/m

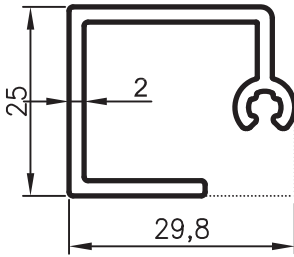

No : 11 236

Askı Profili
0,475 kg/m

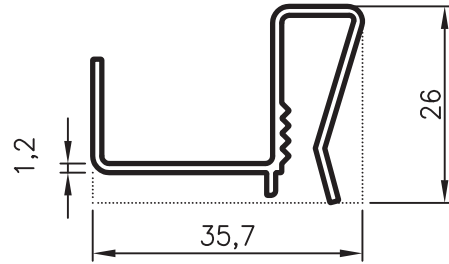

No : 11 257

Kitleme Profili
0.330 kg/m

Genişlik 120cm ye kadar tam ortadan 1 adet, 100mm boyunda olacak.
120cm ve üzeri ise, 2 şer adet sağlı sollu konulacak.

- Profiller
- Profiles

Kompozit Panel Cephe Kaplama Sistemi

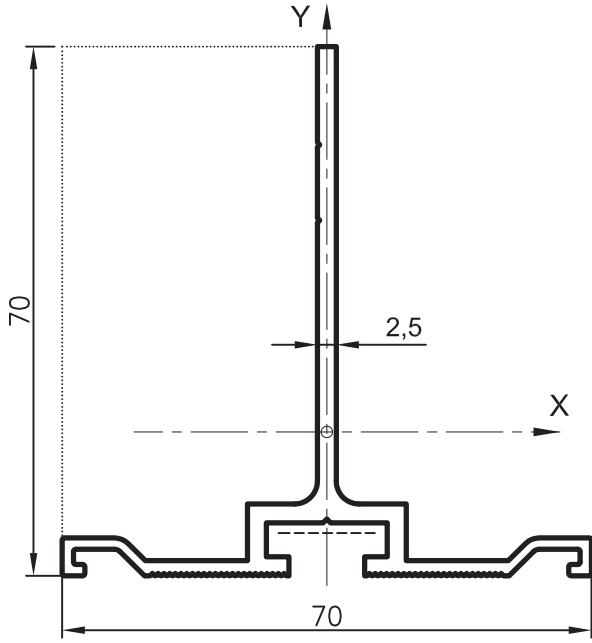

No : 8598

Taşıyıcı Profil
0,910 kg/m

$J_x=16.00 \text{ cm}^4$
 $J_y= 7.01 \text{ cm}^4$

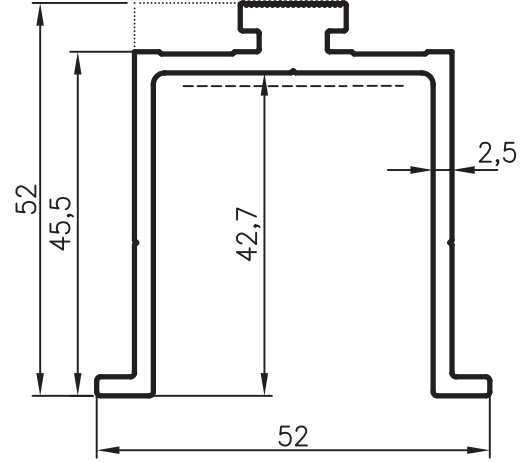

No : 8599

Kitleme Profili
1,160 kg/m

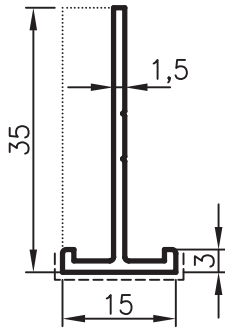

No : 8707

Derz Profili
0,215 kg/m

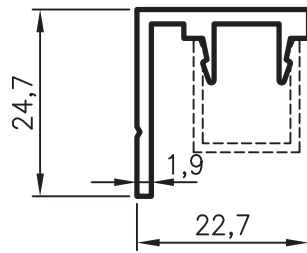

No : 10332

Panel Bağlantı Profili
0,315 kg/m

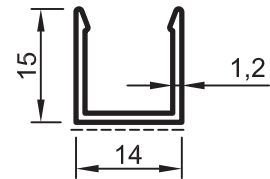

No : 10333

Kapak Profili
0,135 kg/m

Uyarı: Profil ağırlıklarımız teorik olup; teslim anındaki tartımız geçerlidir.
Warning: the weights of profile is theoretical, weighting at the time of delivery are valid.

- Profiller
- Profiles

Kompozit Panel Cephe Kaplama Sistemi

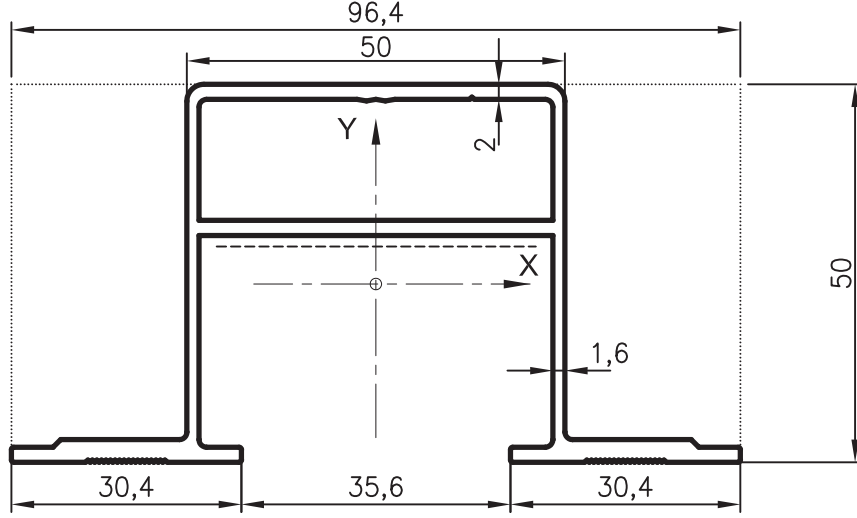

No : 10234

Taşıyıcı U Profil
1,335 kg/m

$J_x=17.09 \text{ cm}^4$
 $J_y=30.12 \text{ cm}^4$

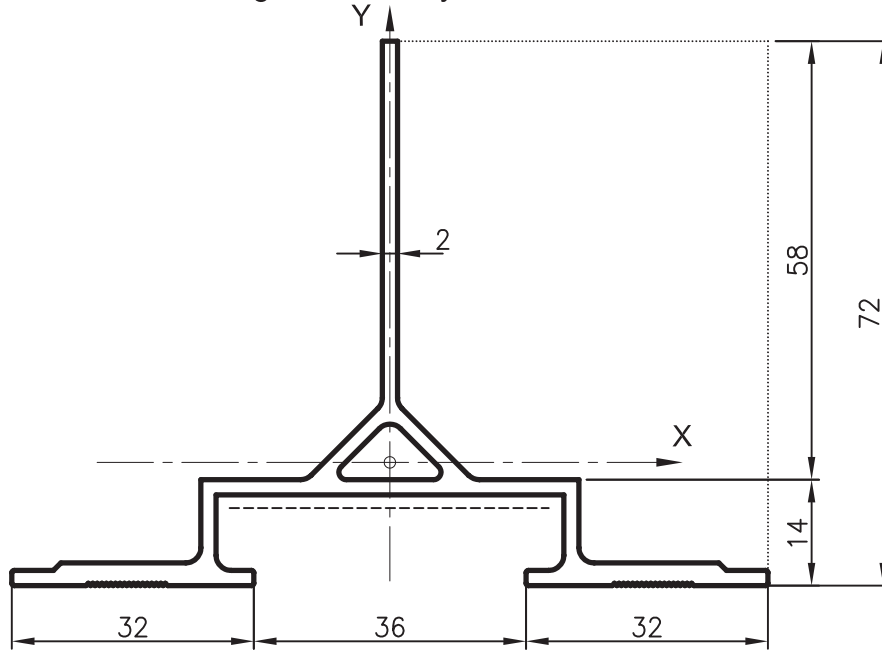

No : 10293

Taşıyıcı T Profil
1,245 kg/m

$J_x= 15.75 \text{ cm}^4$
 $J_y= 24.88 \text{ cm}^4$

Uyarı: Profil ağırlıklarımız teorik olup; teslim anındaki tartımız geçerlidir.
Warning: the weights of profile is theoretical, weighting at the time of delivery are valid.

- Profiller
- Profiles

Kompozit Panel Cephe Kaplama Sistemi

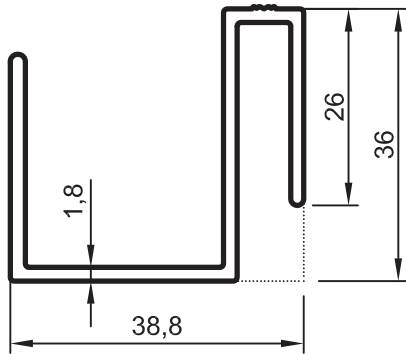

No : 10235

Kompozit Askı Profil
0,625 kg/m

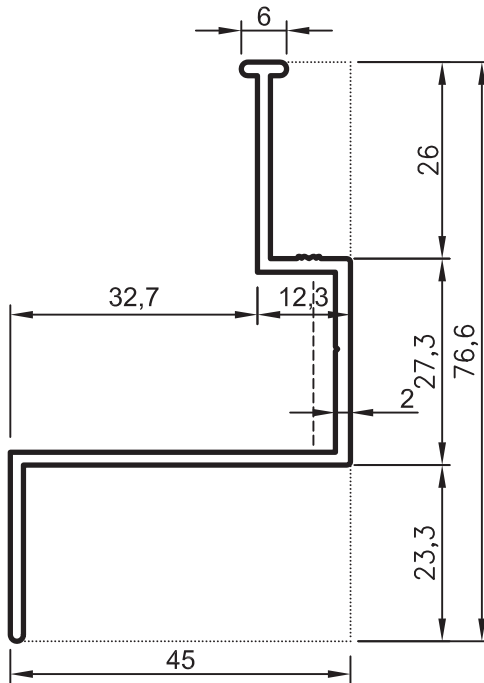

No : 10236

Kompozit Askı Profil
0,655 kg/m

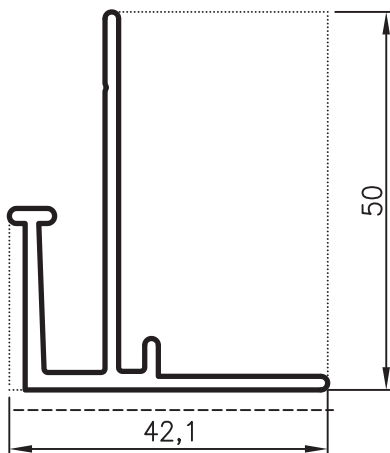

No : 10237

Kompozit Başlangıç Profil
0,620 kg/m

- Profiller
- Profiles

Kompozit Panel Cephe Kaplama Sistemi

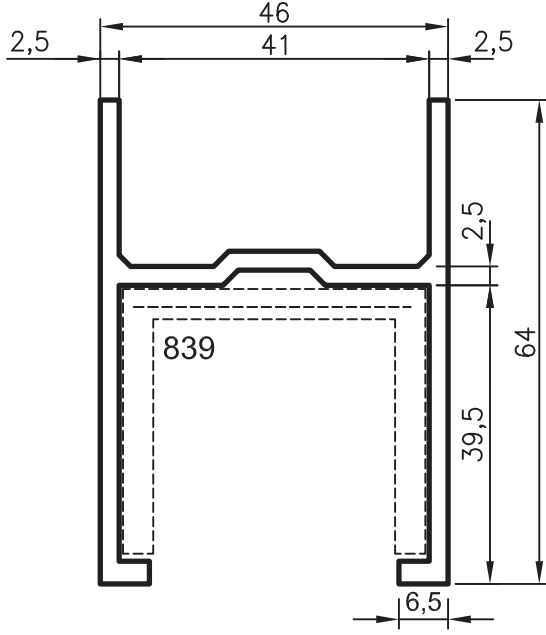

No : 5182

Kompozit Panel Prf.
1,230 kg/m

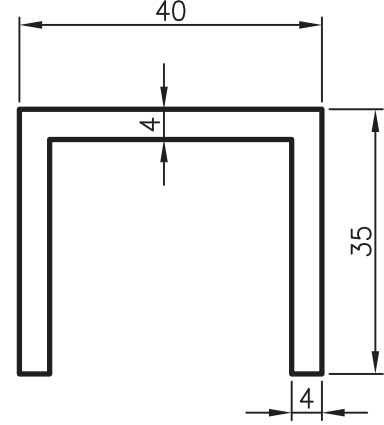

No : 839

U Profili
1,110 kg/m

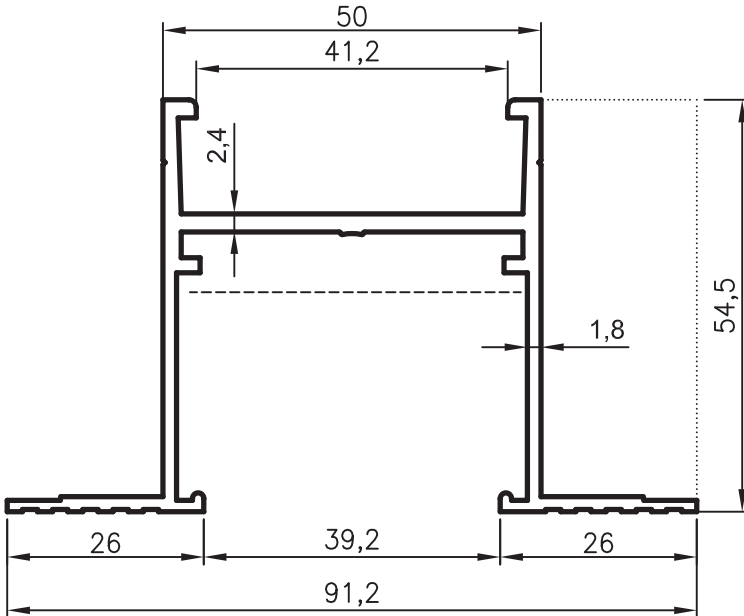

No : 7168

Kompozit Panel Prf.
1,170 kg/m



No : 504

Ø 8 Dolu Çubuk
0,140 kg/m

Uyarı: Profil ağırlıklarımız teorik olup; teslim anındaki tartımız geçerlidir.
Warning: the weights of profile is theoretical, weighting at the time of delivery are valid.

- Profiller
- Profiles

Kompozit Panel Cephe Kaplama Sistemi

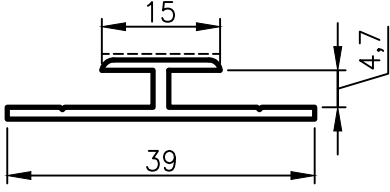

No : 3452

Kompozit Panel
Ek Yeri Profili
0.245 kg/m

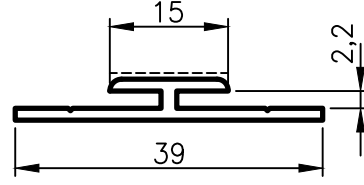

No : 3453

Levha Ek Yeri Profili
0.230 kg/m

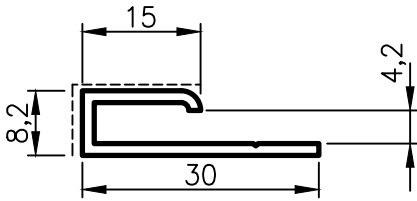

No : 3454

Kompozit Panel
Bitiş Profili
0.205 kg/m

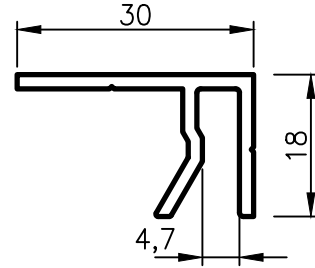

No : 3958

F Profil
Bitiş Profili
0.320 kg/m

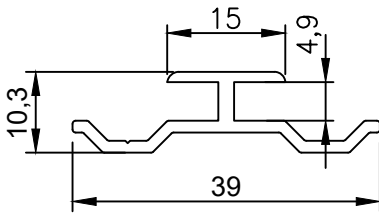

No : 19812

Kompozit Panel Ek Yeri Profili
Joint Profile for Composite Panel
0.255 kg/m

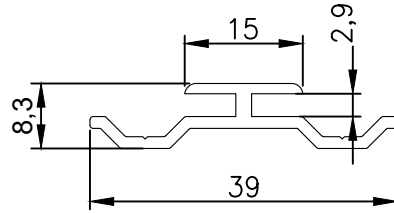

No : 19813

Kompozit Panel Ek Yeri Profili
Joint Profile for Composite Panel
0.245 kg/m

- Ankrajlar
- Anchor

Kompozit Panel Cephe Kaplama Sistemi

L BRAKETLER

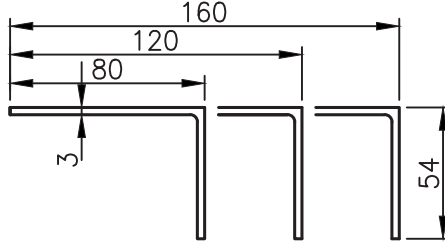

No : 4747
54X80 L
1,075 kg/m

No : 4748
54X120 L
1,400 kg/m

No : 4749
54X160 L
1,725 kg/m

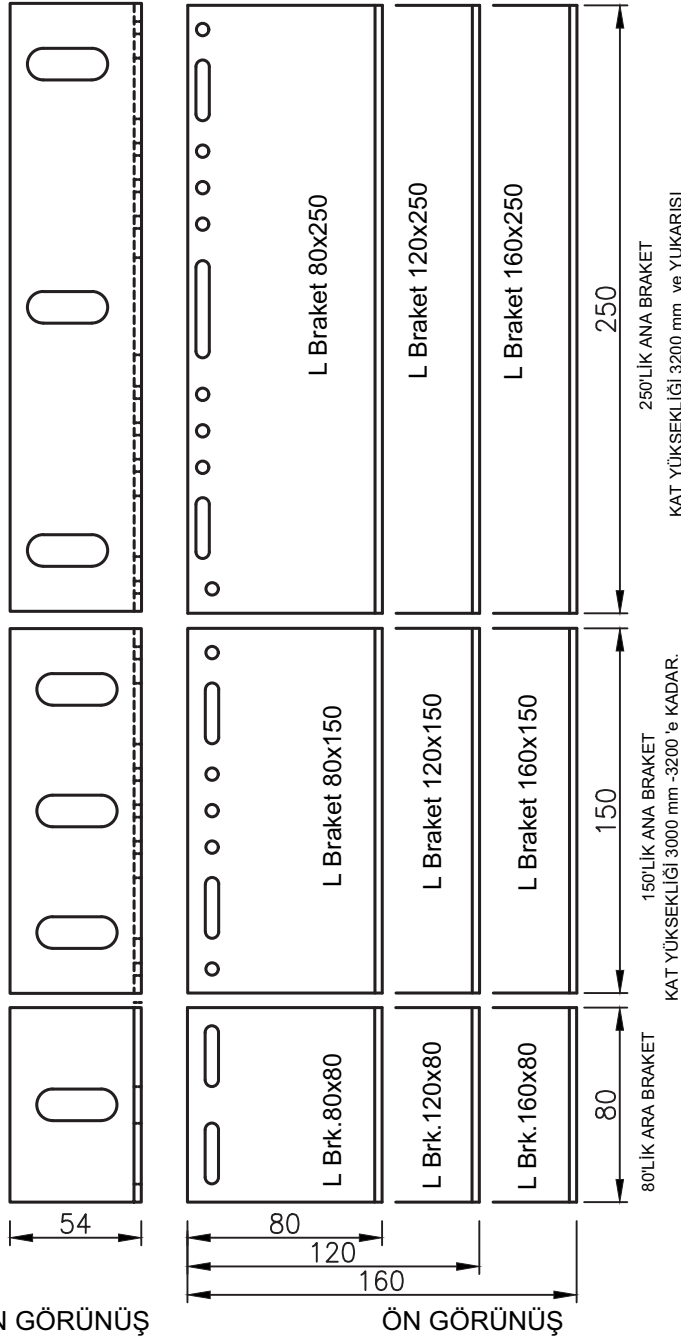

ÖLÇEKSİZ

Uyarı: Profil ağırlıklarımız teorik olup; teslim anındaki tartımız geçerlidir.
Warning: the weights of profile is theoretical, weighting at the time of delivery are valid.

- Ankrajlar
- Anchor

Kompozit Panel Cephe Kaplama Sistemi

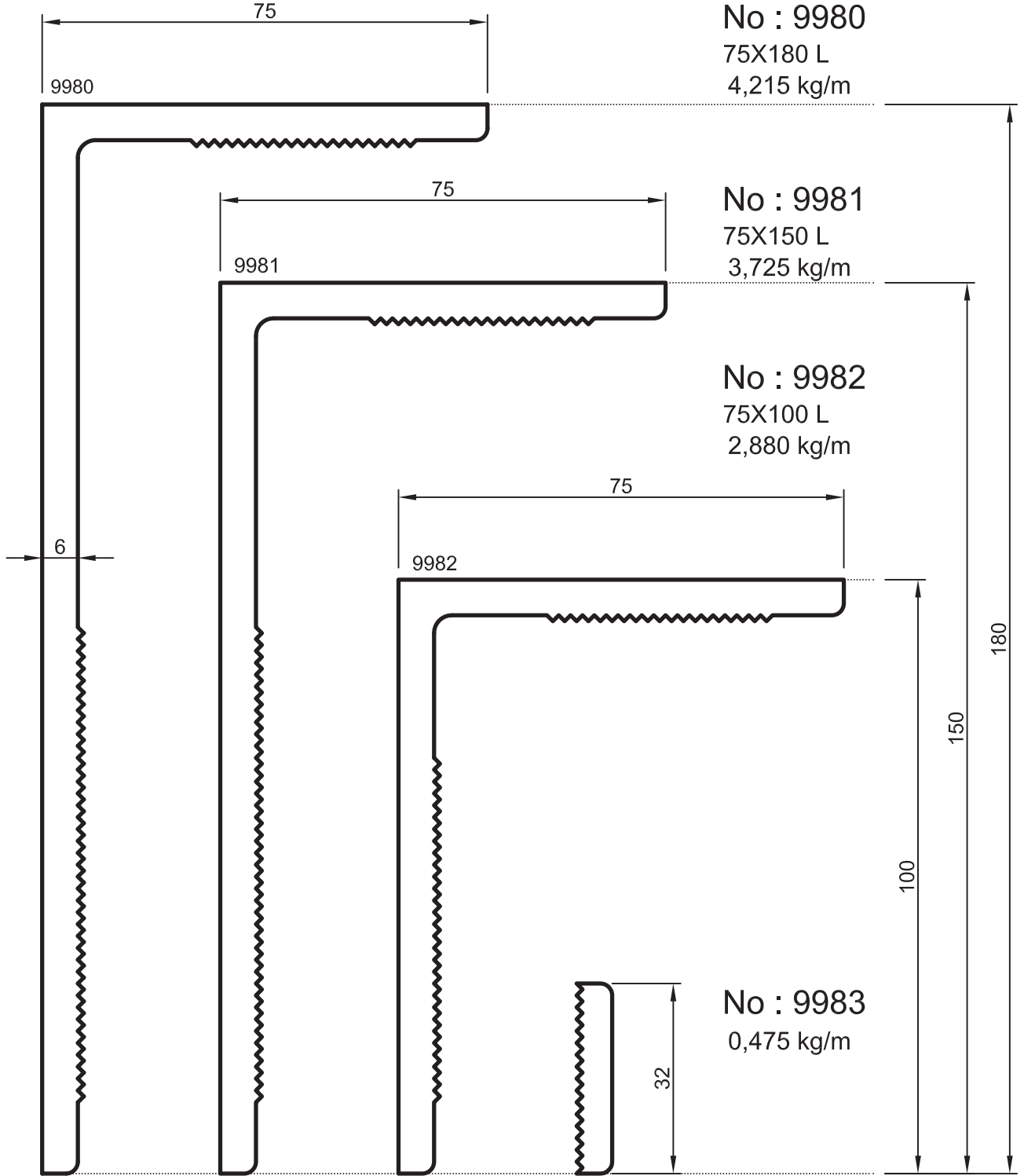

Uyarı: Profil ağırlıklarımız teorik olup; teslim anındaki tartımız geçerlidir.
Warning: the weights of profile is theoretical, weighting at the time of delivery are valid.

**SARAY KOMPOZİT
SİSTEM I DETAYLAR**

***SARAY COMPOSITE
SYSTEMS I DETAILS***

- Detaylar
- Details

Kompozit Panel Cephe Kaplama Sistemi

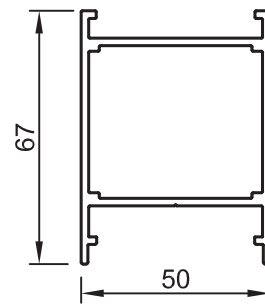
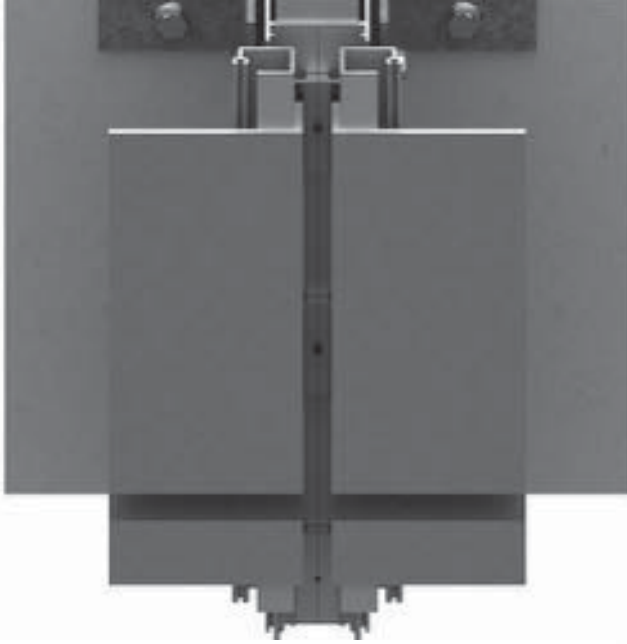

Ölçek:1 / 2

No : 11 221

Taşıyıcı H Profili
1,310 kg/m

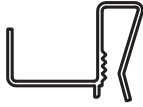

No : 11 257

Kitleme Profili
0.330 kg/m

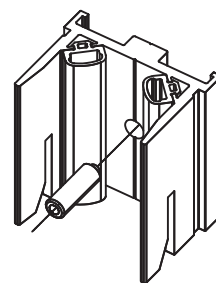
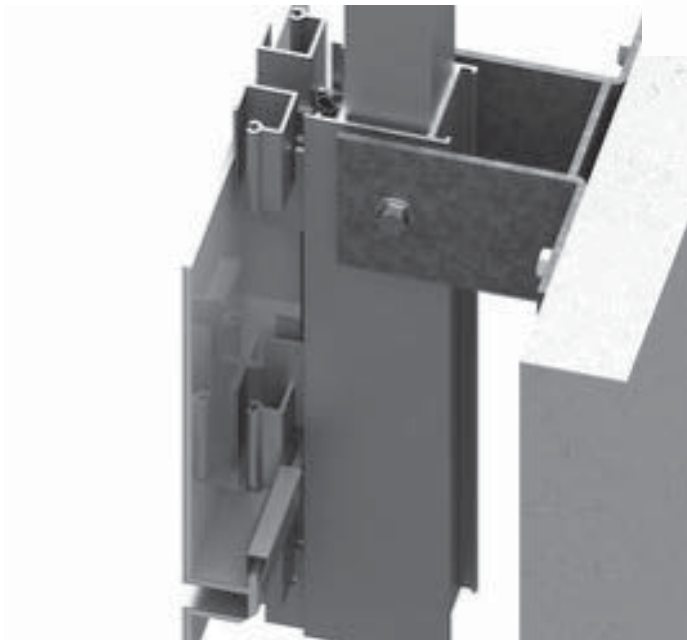
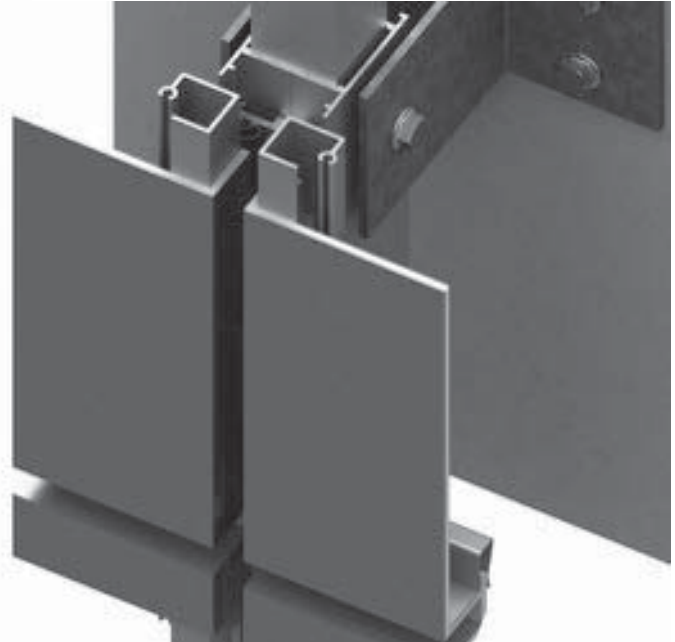

SC-517

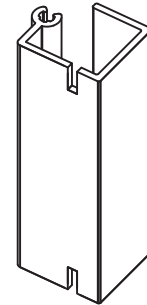

SC-518

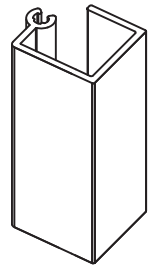

SC-519

Uyarı: Profil ağırlıklarımız teorik olup; teslim anındaki tartımız geçerlidir.
Warning: the weights of profile is theoretical, weighting at the time of delivery are valid.

- Detaylar
- Details

Kompozit Panel Cephe Kaplama Sistemi

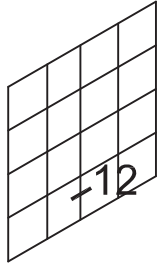

Detay
Detail 12

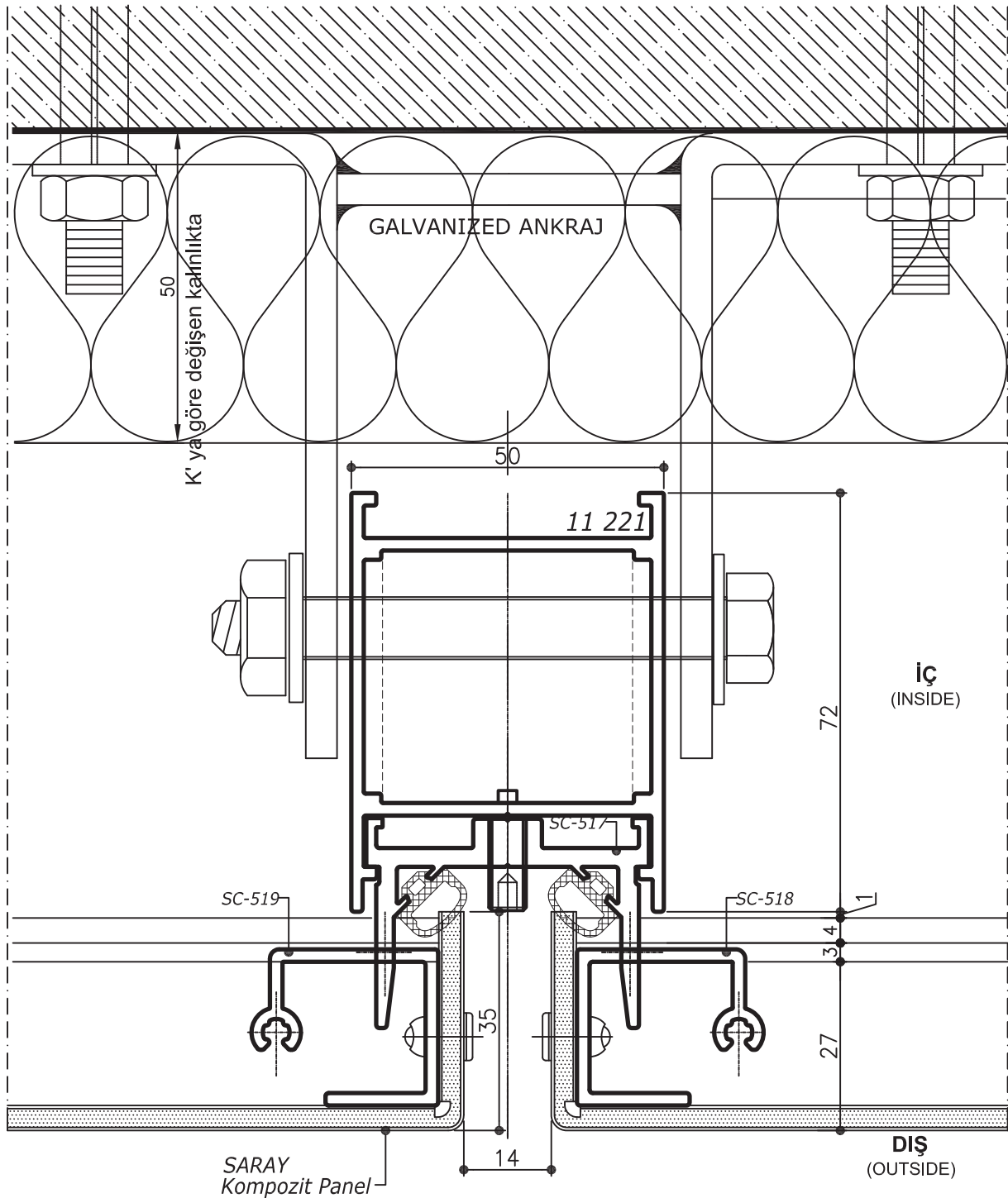

- Detaylar
- Details

Kompozit Panel Cephe Kaplama Sistemi

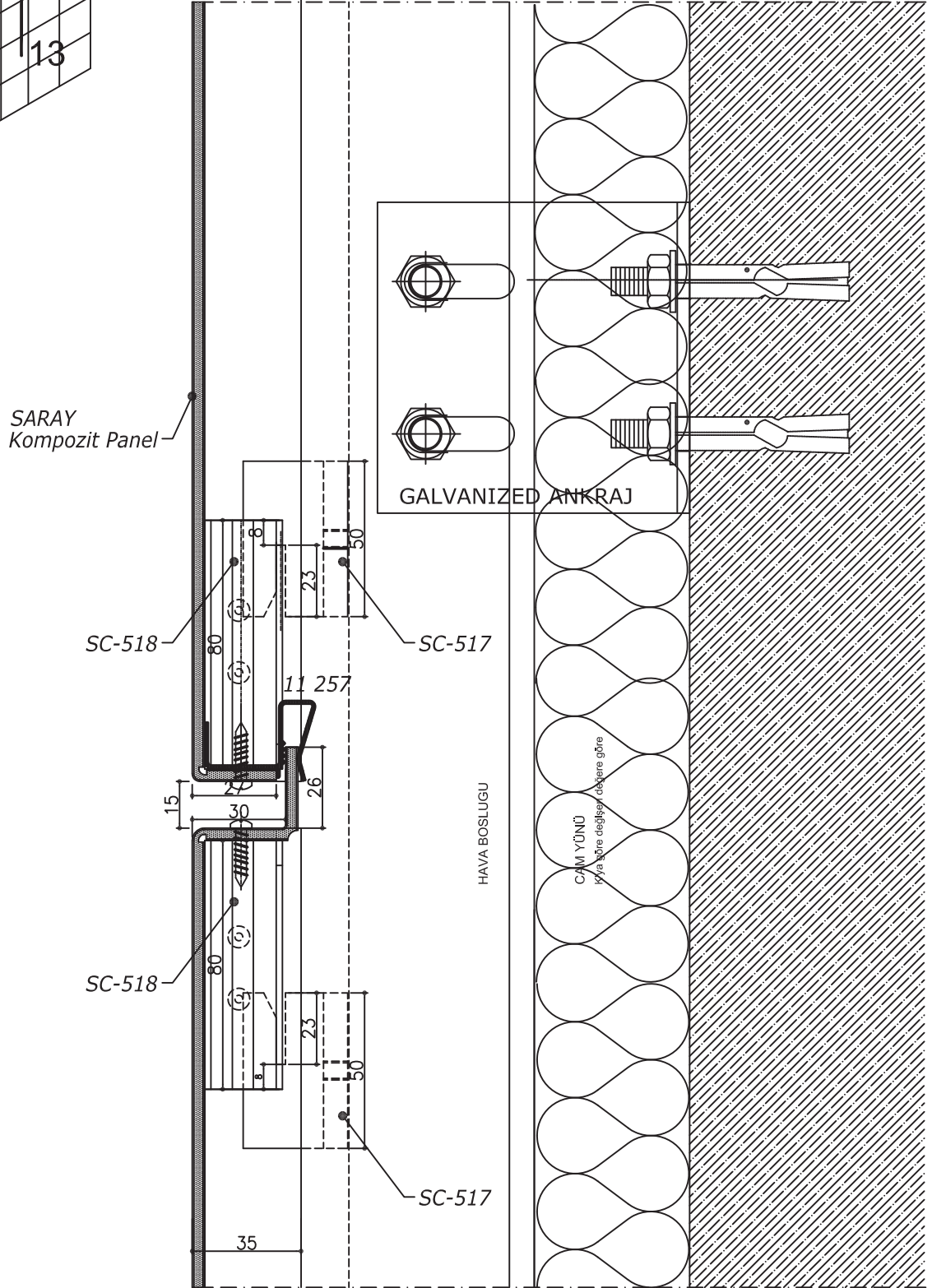
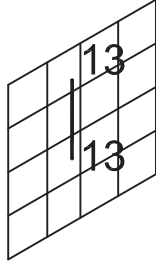

Ölçek:1 / 2

Detay
Detail 13

- Detaylar
- Details

Kompozit Panel Cephe Kaplama Sistemi

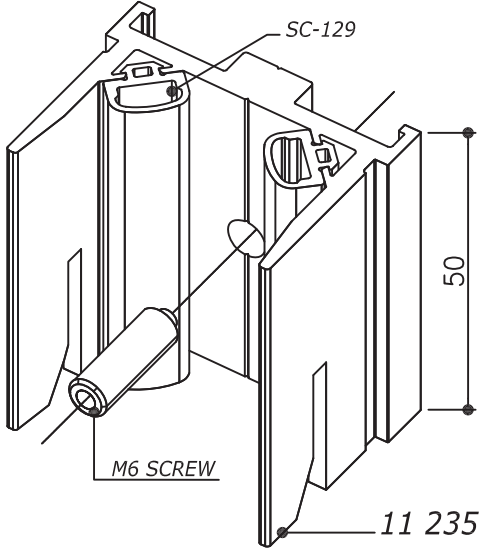

SC-517

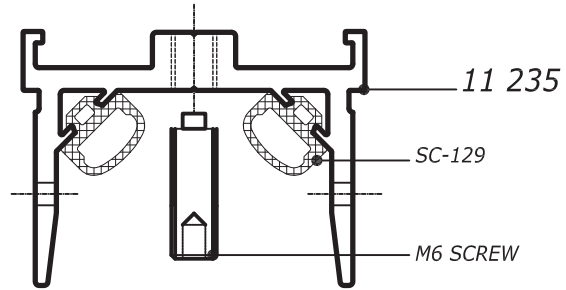
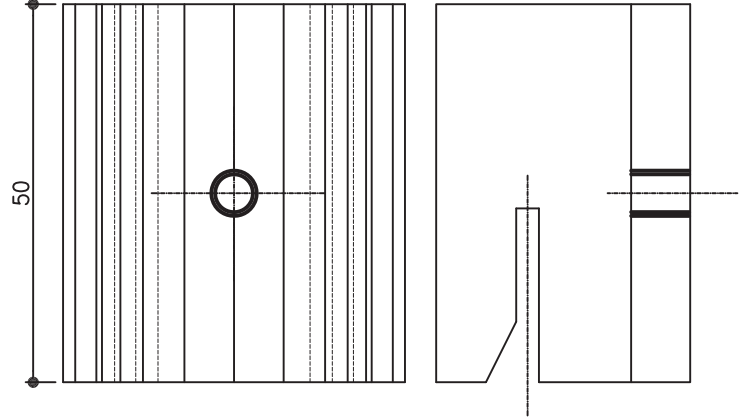

SC-518

Pr. No: 11 236

80 mm boyunda kesilmiş olarak satılır.

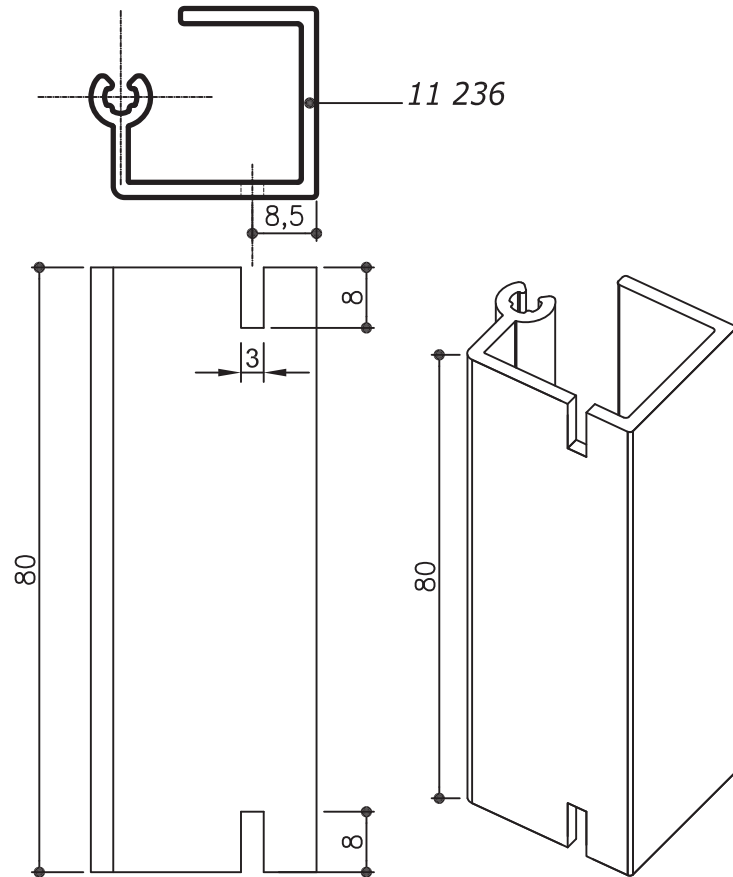

SC-519

Pr. No: 11 236

72mm boyunda kesilecek.
Profil olarak satılır.

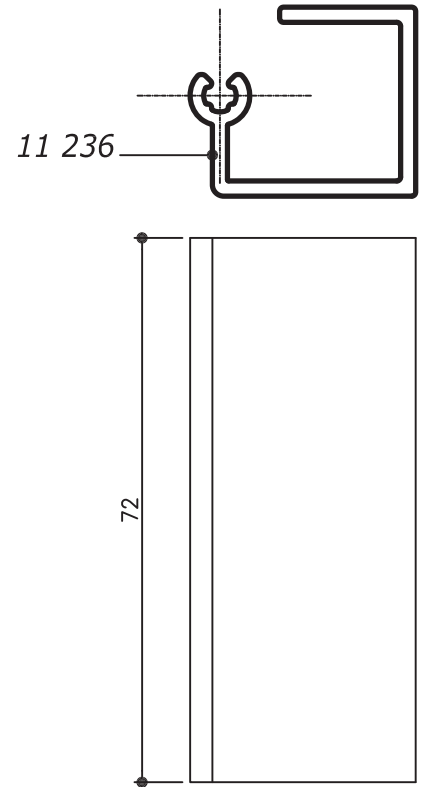

- Detaylar
- Details

Kompozit Panel Cephe Kaplama Sistemi

Örnek Kompozit İmalat Paftası

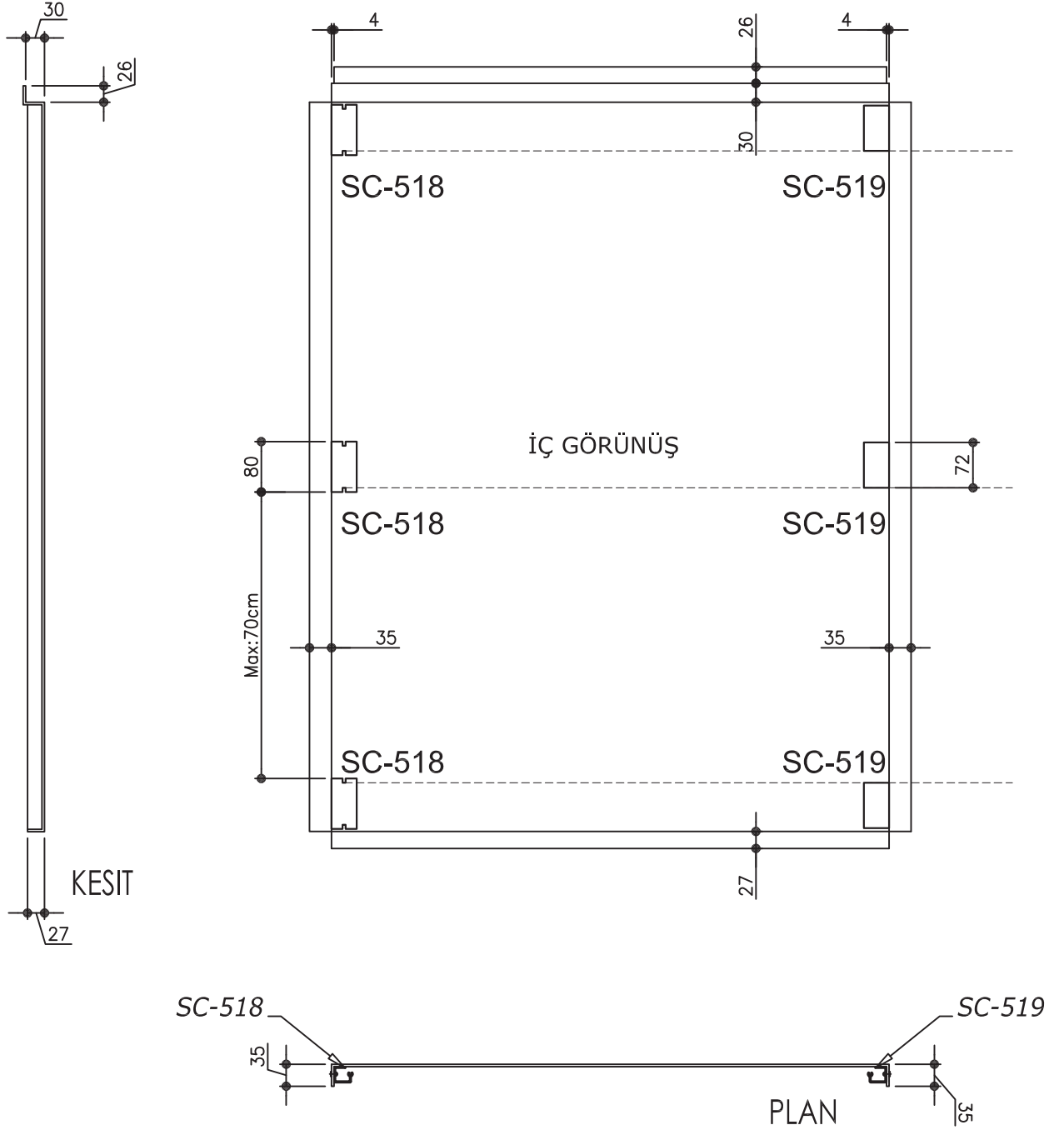

Dikkat:

Kompozit panel kalınlıkları ve montaj detayları; projeye, bina yüksekliği ve bölgenin rüzgar yüklerine göre statik hesap değerlerini karşılayacak şekilde seçilip uygulanmalıdır.

- Detaylar
- Details

Kompozit Panel Cephe Kaplama Sistemi

Örnek Kompozit Montaj Paftası

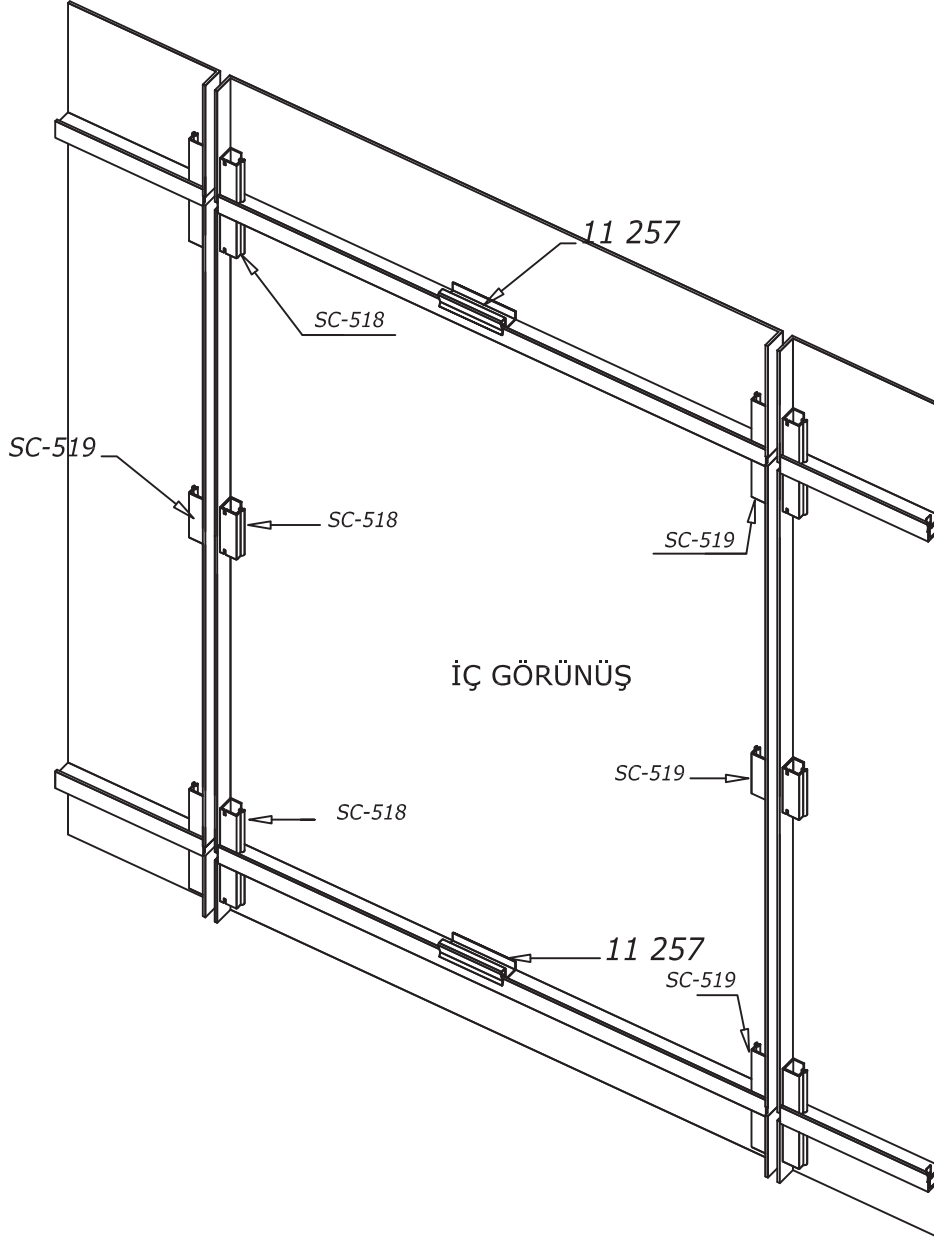

Dikkat:

Kompozit panel kalınlıkları ve montaj detayları; projeye, bina yüksekliği ve bölgenin rüzgar yüklerine göre statik hesap değerlerini karşılayacak şekilde seçilip uygulanmalıdır.

- Detaylar
- Details

Kompozit Panel Cephe Kaplama Sistemi

Örnek Kompozit Montaj Paftası

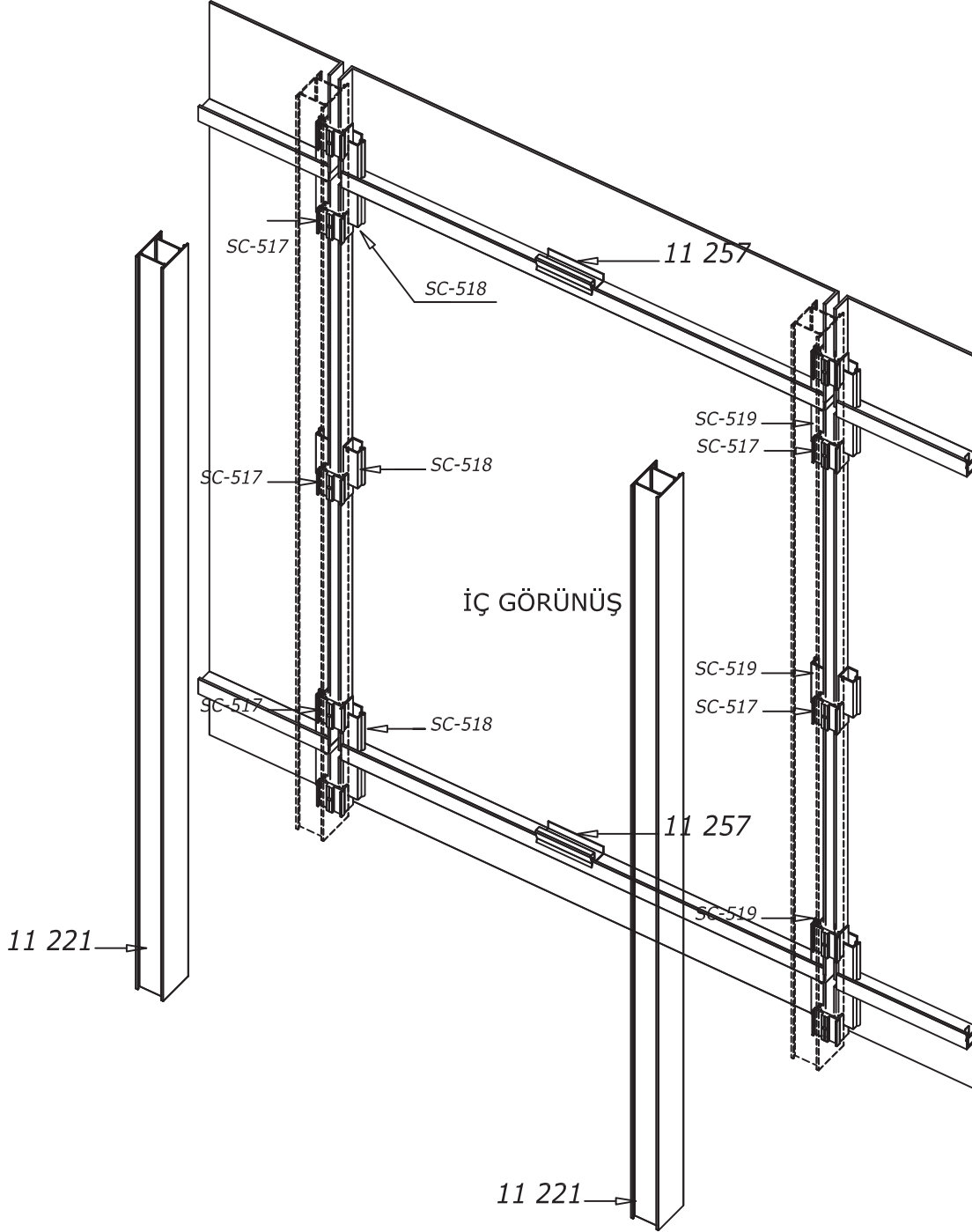
**Dikkat:**

Kompozit panel kalınlıkları ve montaj detayları; projeye, bina yüksekliği ve bölgenin rüzgar yüklerine göre statik hesap değerlerini karşılayacak şekilde seçilip uygulanmalıdır.

**SARAY KOMPOZİT
SİSTEM 2 DETAYLAR**

***SARAY COMPOSITE
SYSTEMS 2 DETAILS***

- Detaylar
- Details

Kompozit Panel Cephe Kaplama Sistemi

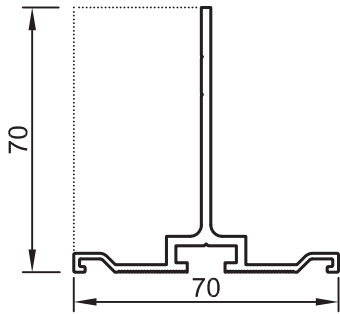
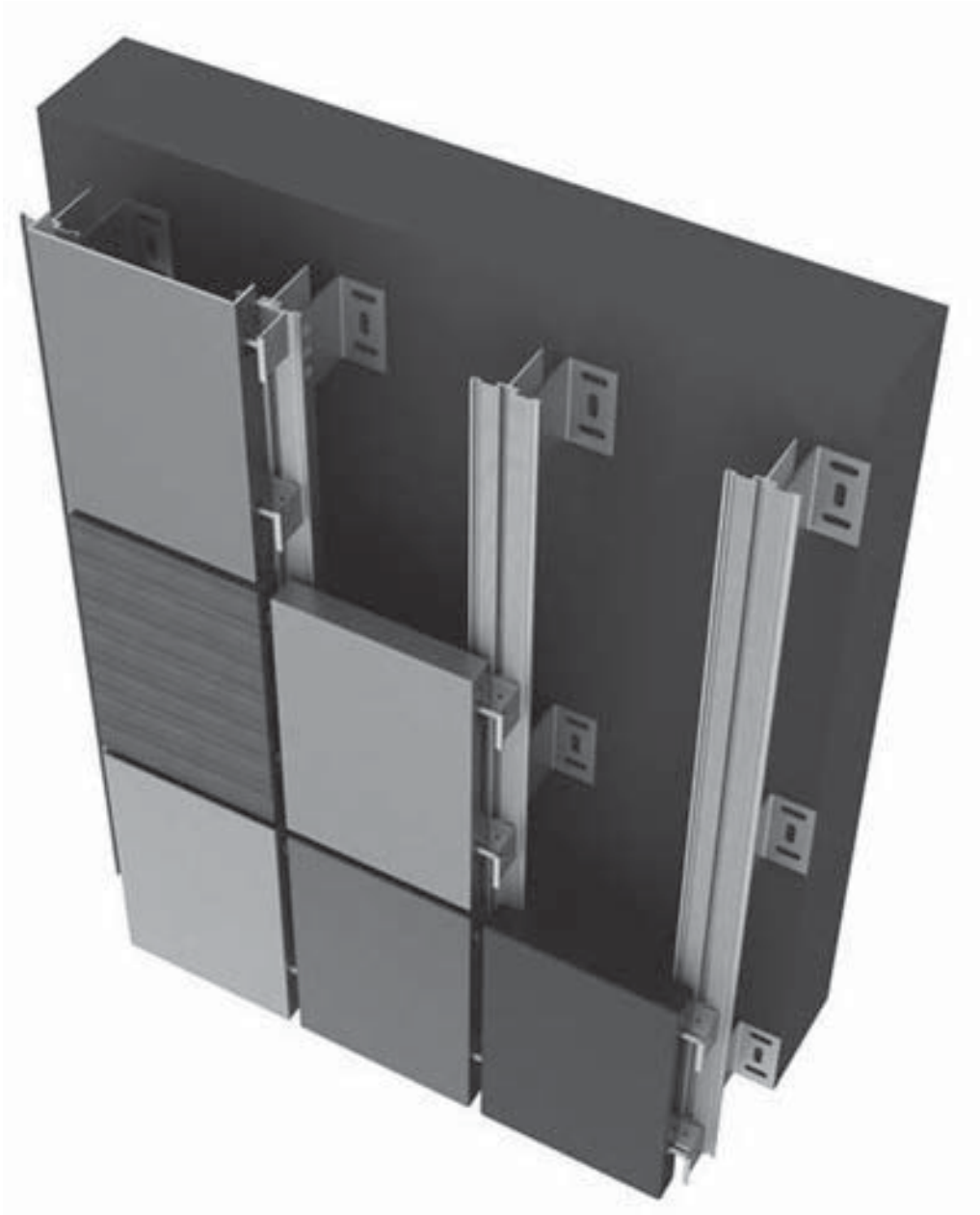

No : 8598

Taşıyıcı Profil
0,910 kg/m

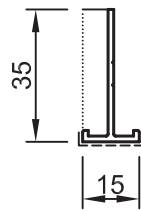

No : 8707

Derz Profil
0,215 kg/m

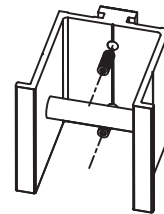

SC-510

Ölçek: 1 / 2

Uyarı: Profil ağırlıklarımız teorik olup; teslim anındaki tartımız geçerlidir.
Warning: the weights of profile is theoretical, weighting at the time of delivery are valid.

- Detaylar
- Details

Kompozit Panel Cephe Kaplama Sistemi

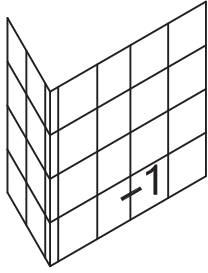

Detay
Detail 1

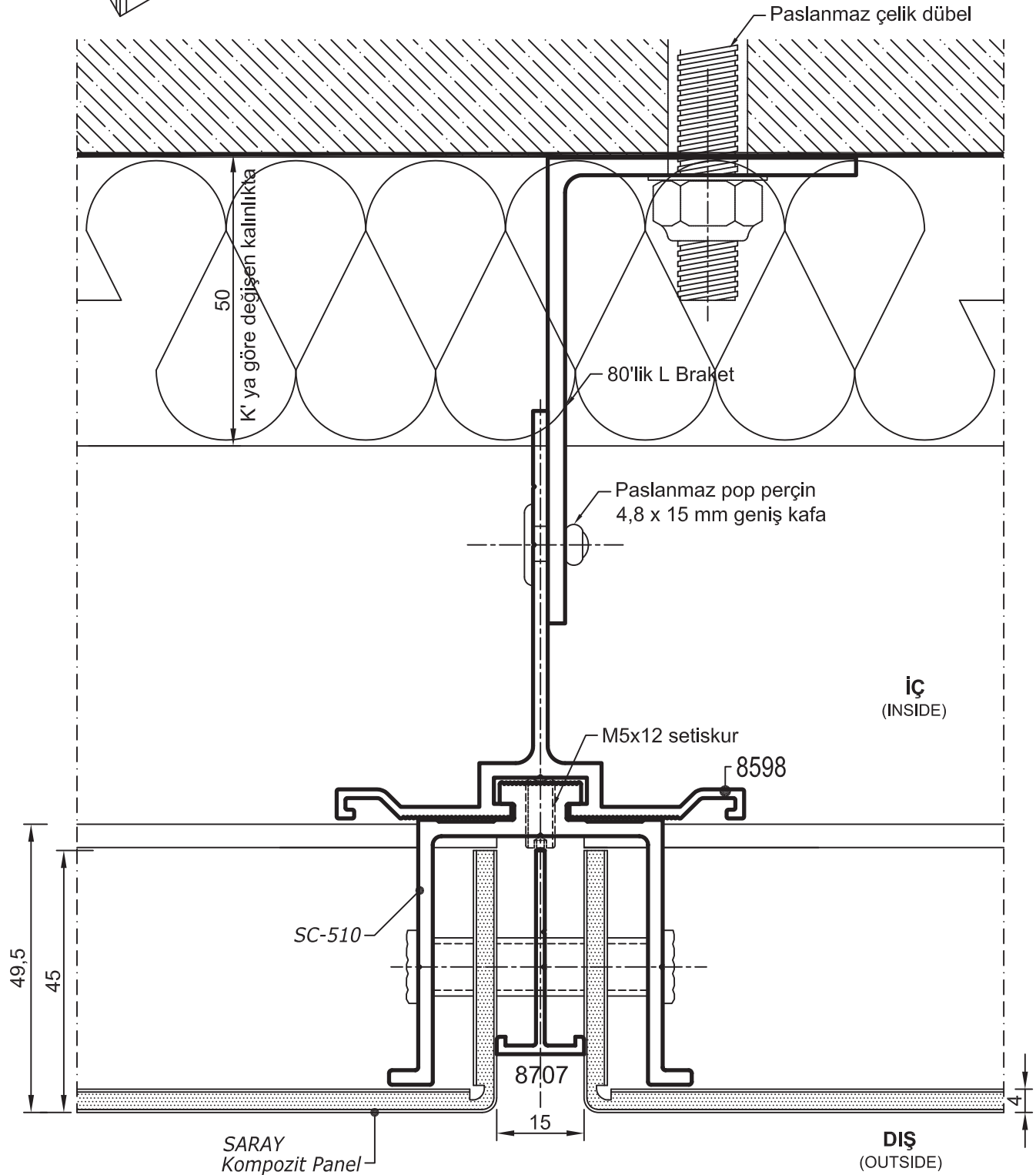

- Detaylar
- Details

Kompozit Panel Cephe Kaplama Sistemi

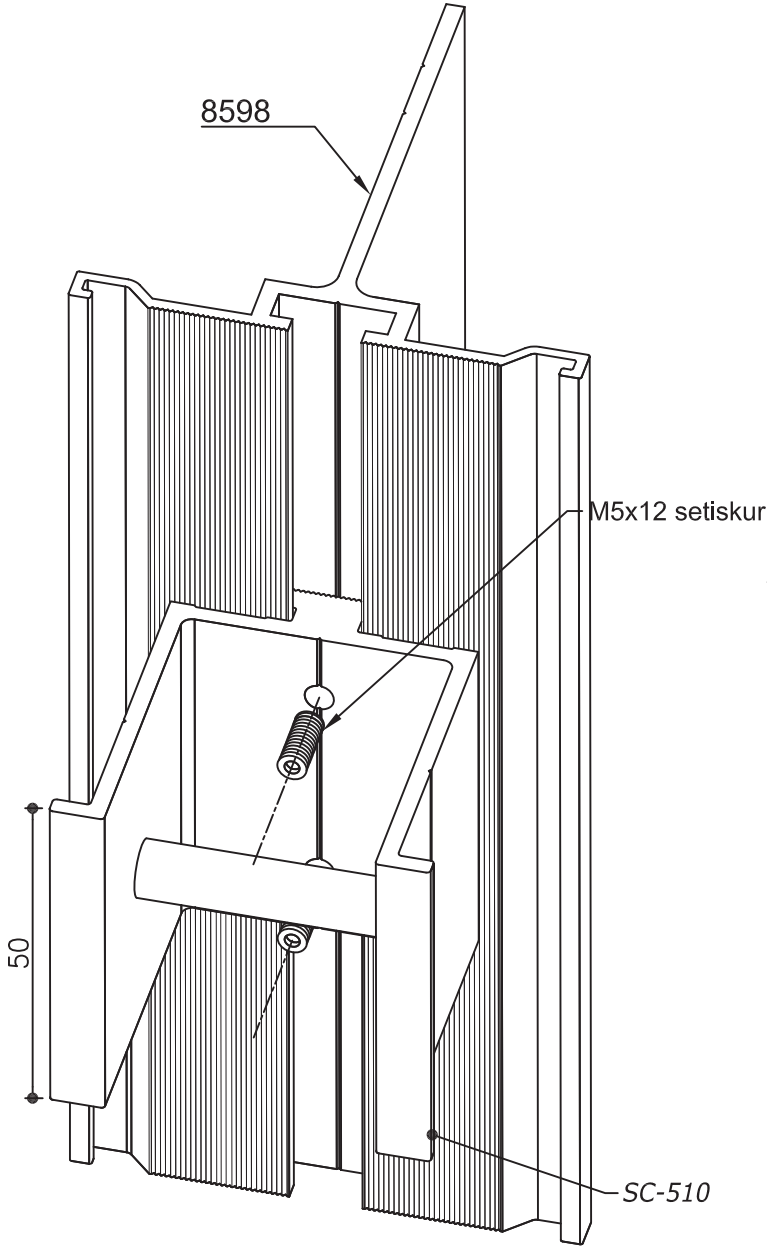

PERSPEKTİF

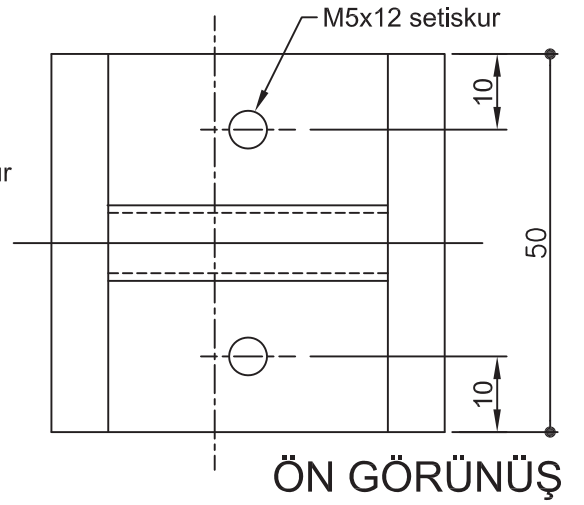

ÖN GÖRÜNÜŞ

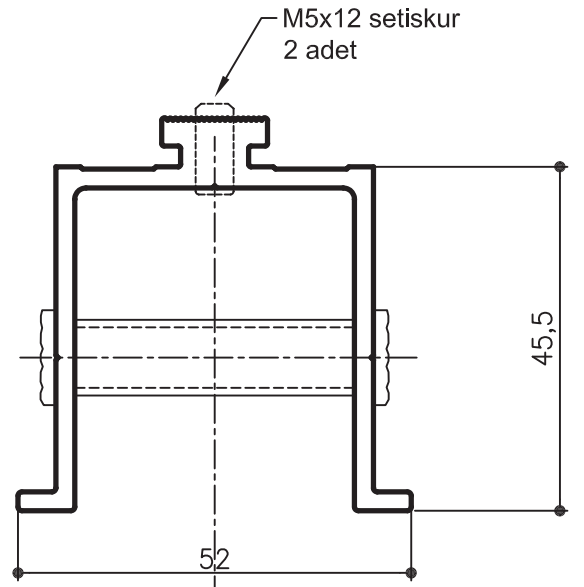

SC-510 (50 tk/pk)

Takım halinde satılır.

Dikkat:

Kompozit panel kalınlıkları ve montaj detayları; projeye, bina yüksekliği ve bölgenin rüzgar yüklerine göre statik hesap değerlerini karşılayacak şekilde seçilip uygulanmalıdır.

- Detaylar
- Details

Kompozit Panel Cephe Kaplama Sistemi

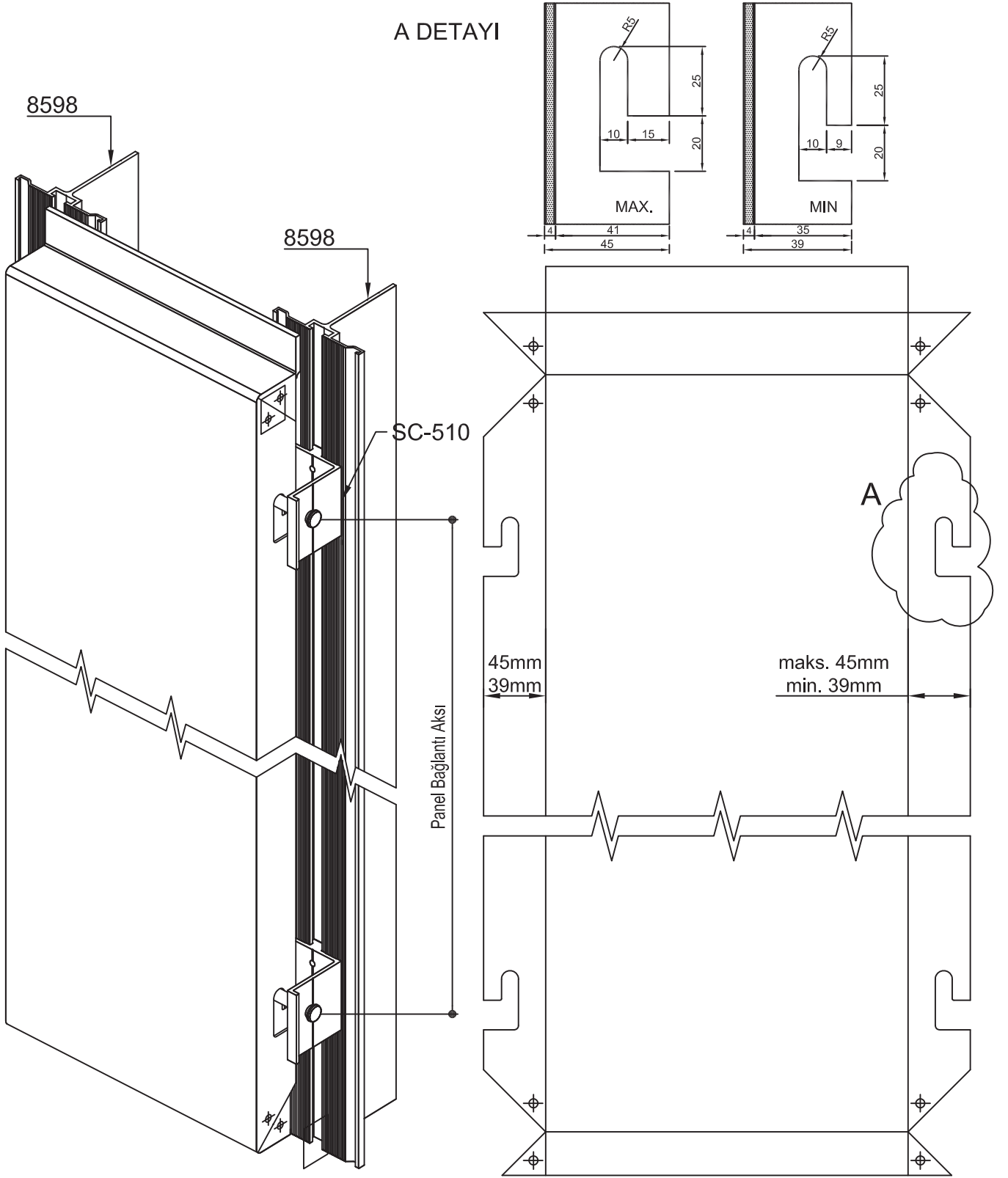

Dikkat:

Kompozit panel kalınlıkları ve montaj detayları; projeye, bina yüksekliği ve bölgenin rüzgar yüklerine göre statik hesap değerlerini karşılayacak şekilde seçilip uygulanmalıdır.

PERSPEKTİF

**SARAY KOMPOZİT
SİSTEM 3 DETAYLAR**

***SARAY COMPOSITE
SYSTEMS 3 DETAILS***

- Detaylar
- Details

Kompozit Panel Cephe Kaplama Sistemi

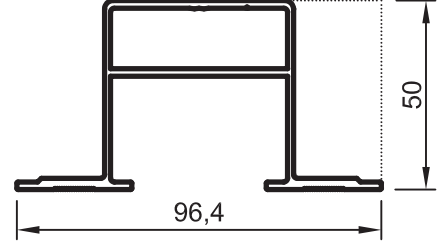
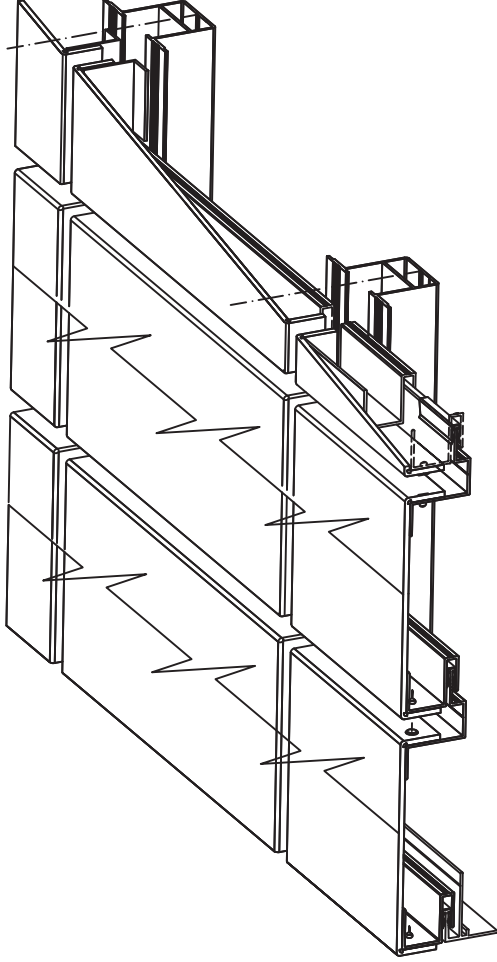

No : 10234

Taşıyıcı U Profil
1,335 kg/m

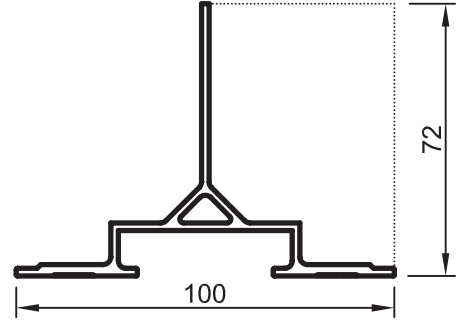

No : 10293

Taşıyıcı T Profil
1,245 kg/m

Ölçek: 1 / 2

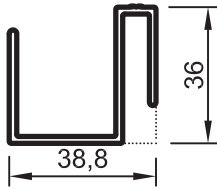

No : 10235

Kompozit Askı Profil
0,625 kg/m

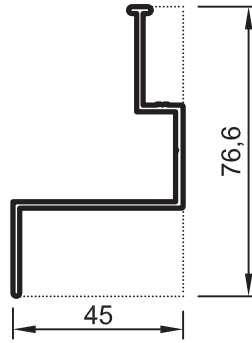

No : 10236

Kompozit Askı Profil
0,655 kg/m

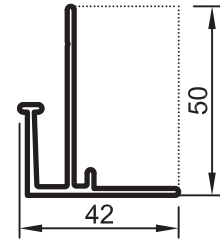

No : 10237

Kompozit Başlangıç Profil
0,620 kg/m

Uyarı: Profil ağırlıklarımız teorik olup; teslim anındaki tartımız geçerlidir.
Warning: the weights of profile is theoretical, weighting at the time of delivery are valid.

- Detaylar
- Details

Kompozit Panel Cephe Kaplama Sistemi

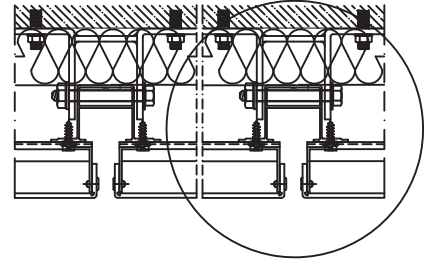
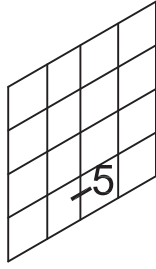

Detay 5
Detail 5

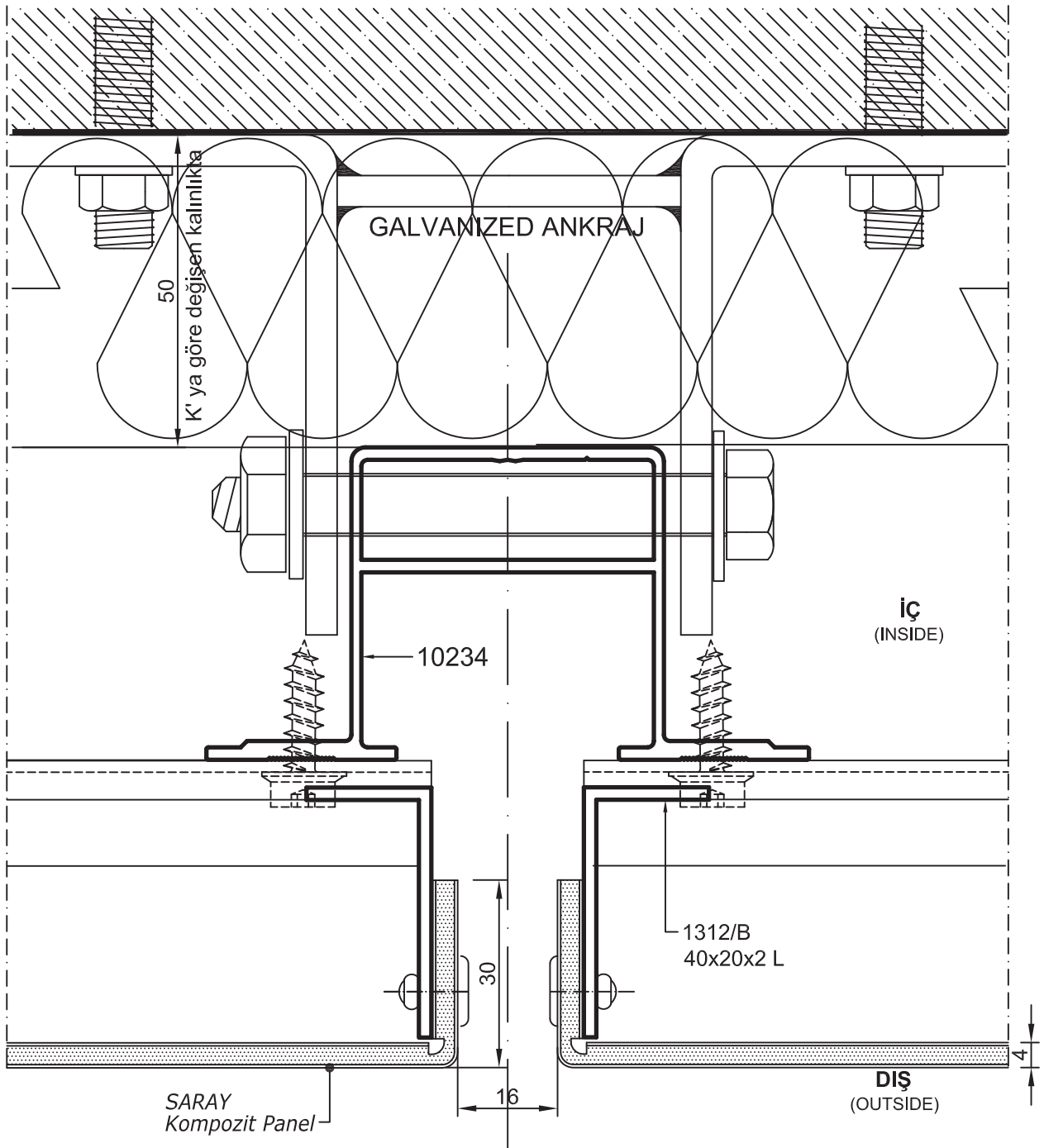

- Detaylar
- Details

Kompozit Panel Cephe Kaplama Sistemi

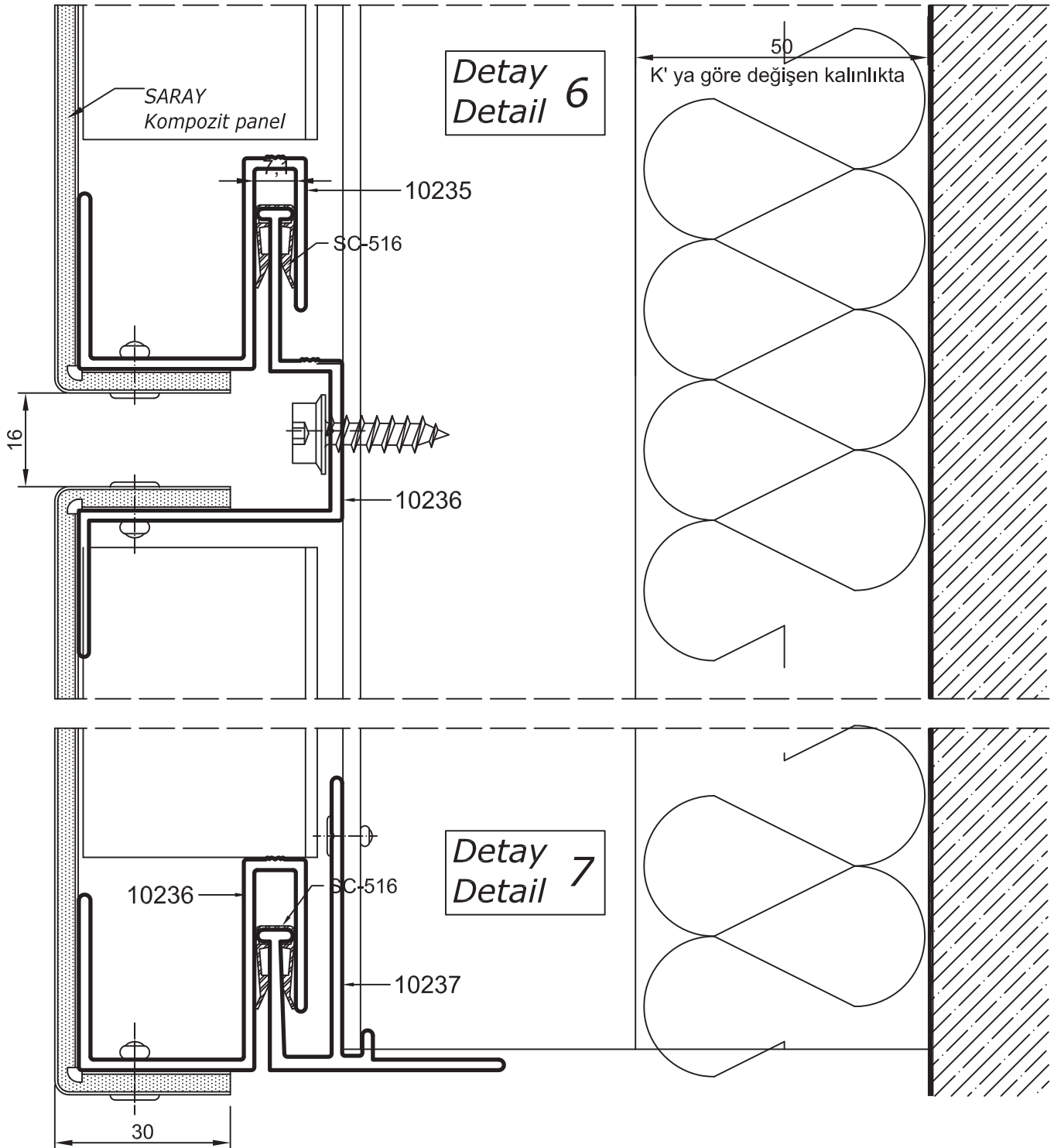
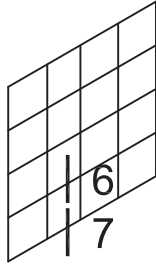

- Detaylar
- Details

Kompozit Panel Cephe Kaplama Sistemi

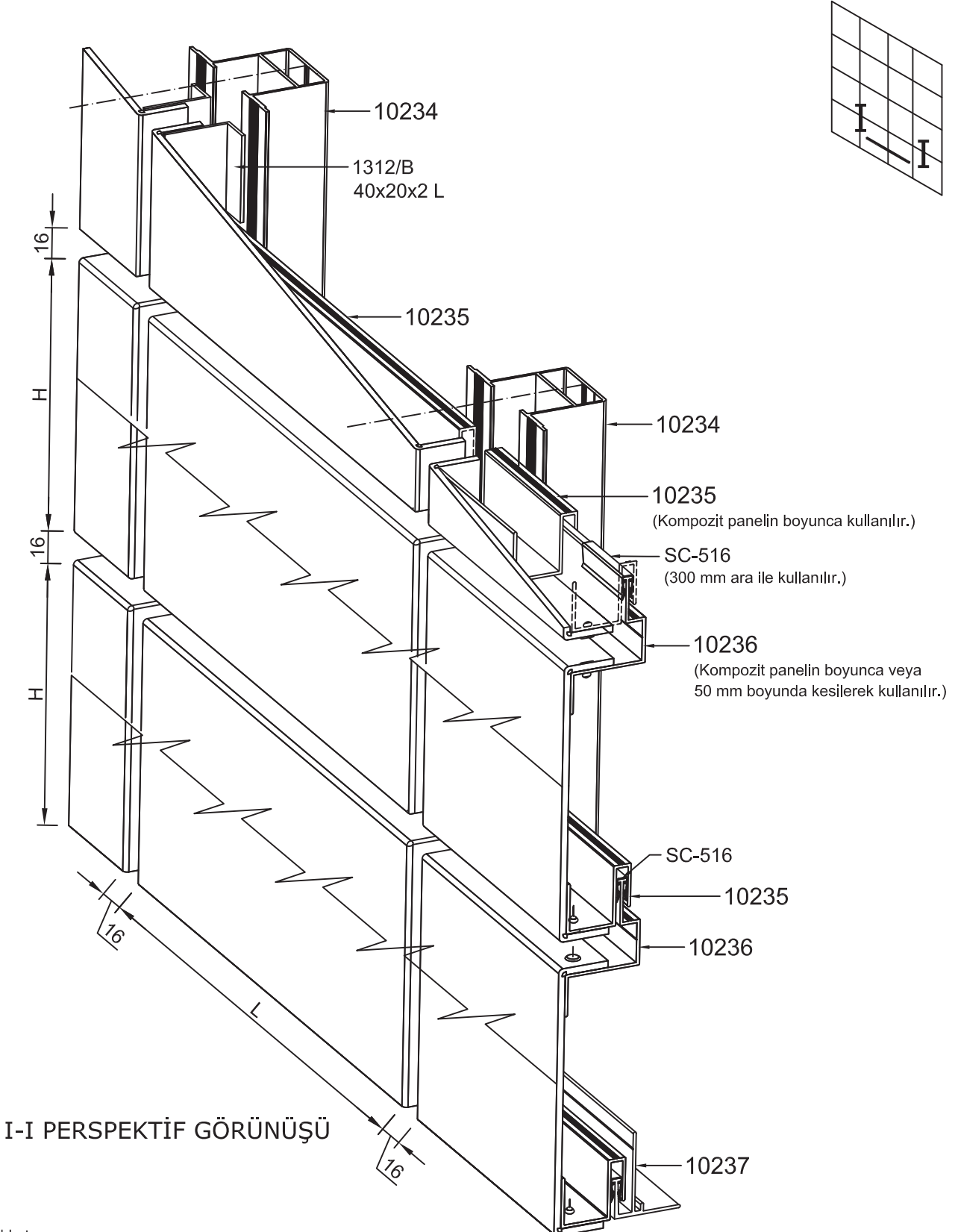

Dikkat:

Kompozit panel kalınlıkları ve montaj detayları; projeye, bina yüksekliği ve bölgenin rüzgar yüklerine göre statik hesap değerlerini karşılayacak şekilde seçilip uygulanmalıdır.

**SARAY KOMPOZİT
SİSTEM 4 DETAYLAR**

***SARAY COMPOSITE
SYSTEMS 4 DETAILS***

- Detaylar
- Details

Kompozit Panel Cephe Kaplama Sistemi

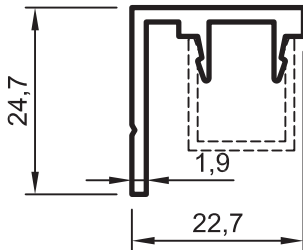
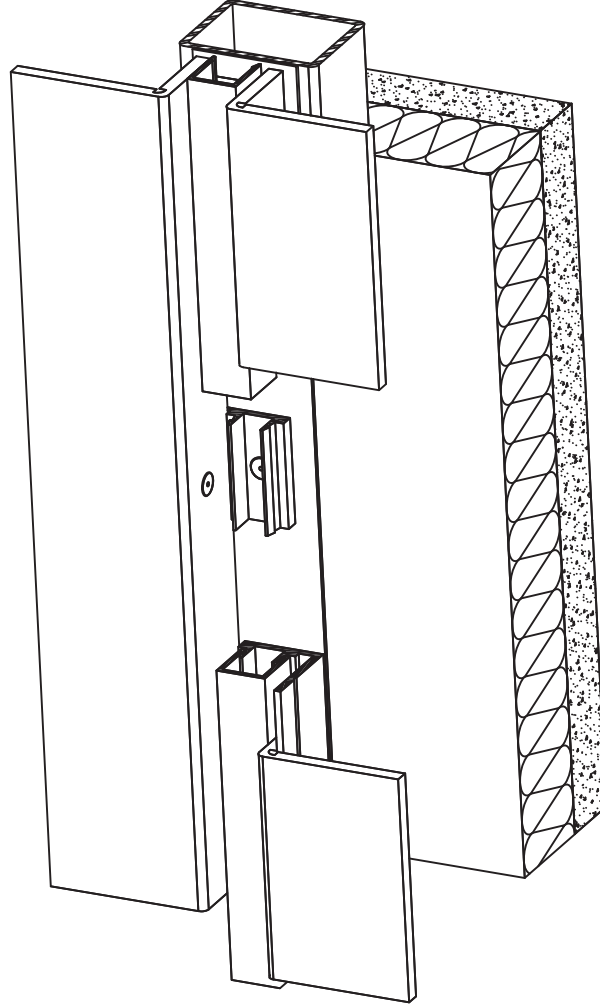

No : 10332

Montaj Profil
0,315 kg/m

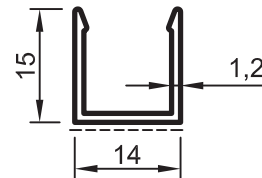

No : 10333

Kapak Profil
0,135 kg/m

Ölçek:1 / 1

Uyarı: Profil ağırlıklarımız teorik olup; teslim anındaki tartımız geçerlidir.
Warning: the weights of profile is theoretical, weighting at the time of delivery are valid.

- Detaylar
- Details

Kompozit Panel Cephe Kaplama Sistemi

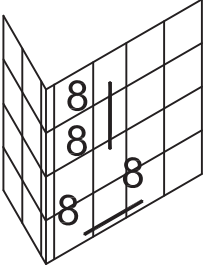

Detay 8-8
Detail 8-8

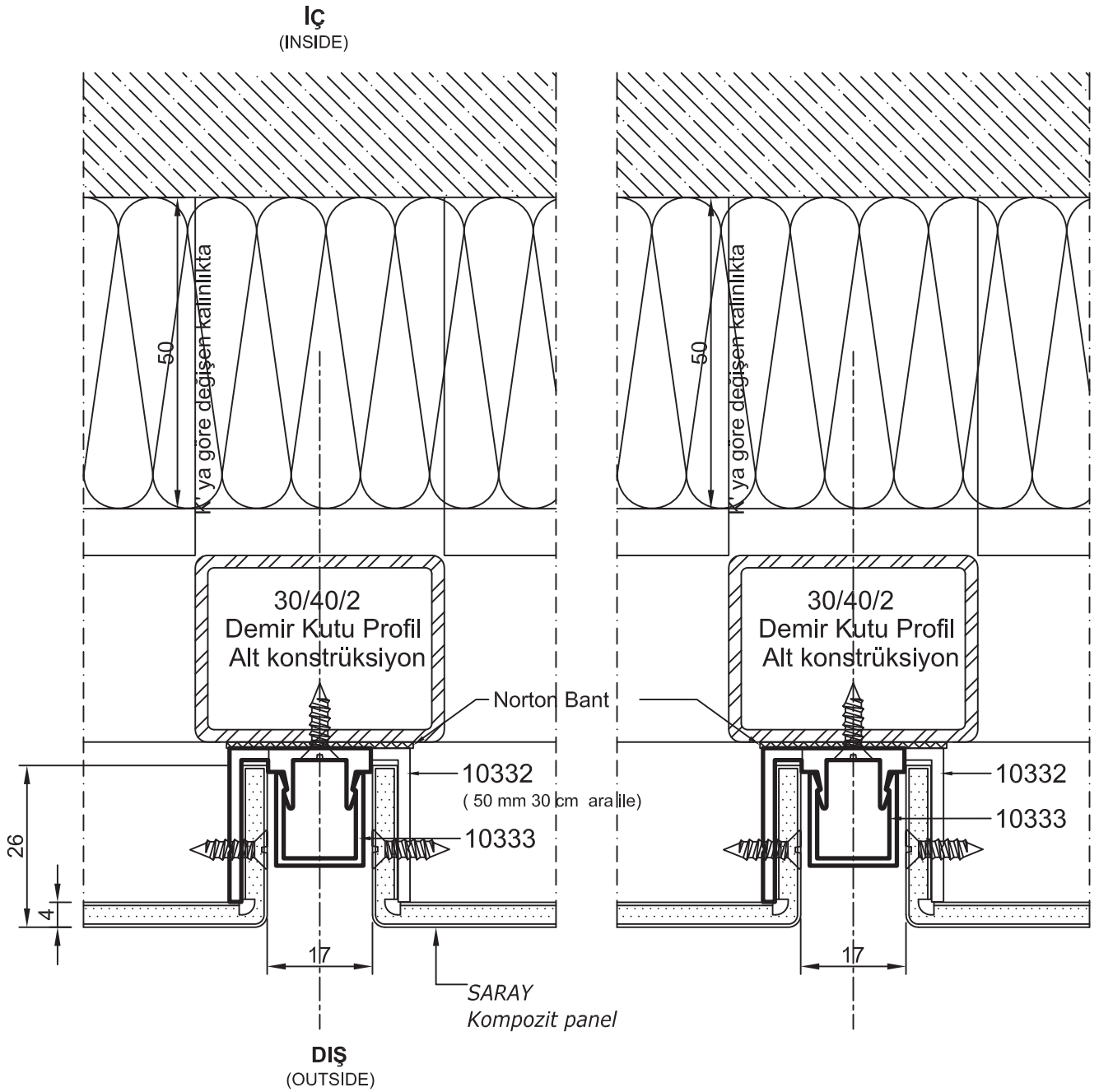

Uyarı: Demir alt konstrüksiyonların antipas işlemi görmüş olmaları gerekmektedir. Demir alt konstrüksiyon statik hesaba göre kullanılmalıdır.

- Detaylar
- Details

Kompozit Panel Cephe Kaplama Sistemi

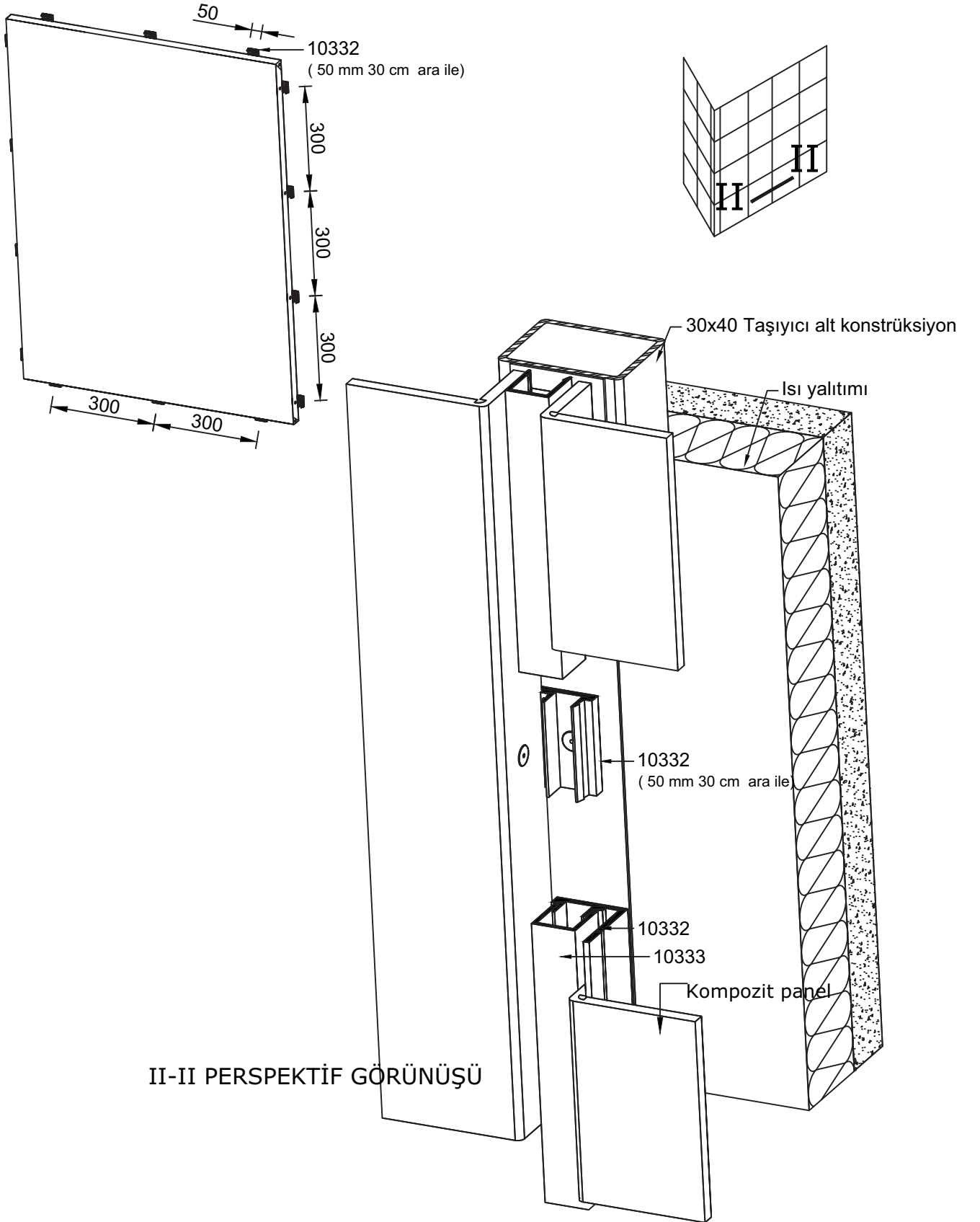

Dikkat:

Kompozit panel kalınlıkları ve montaj detayları; projeye, bina yüksekliği ve bölgenin rüzgar yüklerine göre statik hesap değerlerini karşılayacak şekilde seçilip uygulanmalıdır.

**SARAY KOMPOZİT
SİSTEM 5 DETAYLAR**

***SARAY COMPOSITE
SYSTEMS 5 DETAILS***

- Detaylar
- Details

Kompozit Panel Cephe Kaplama Sistemi

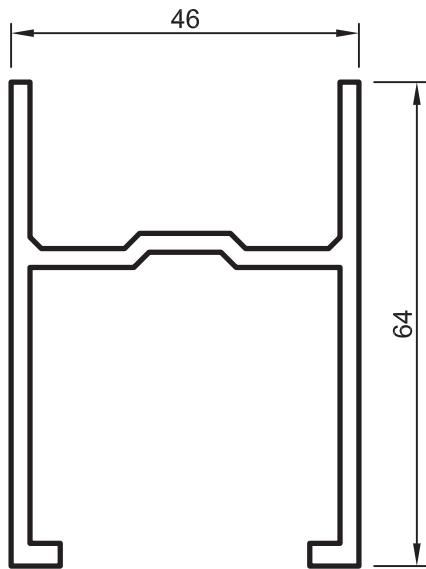
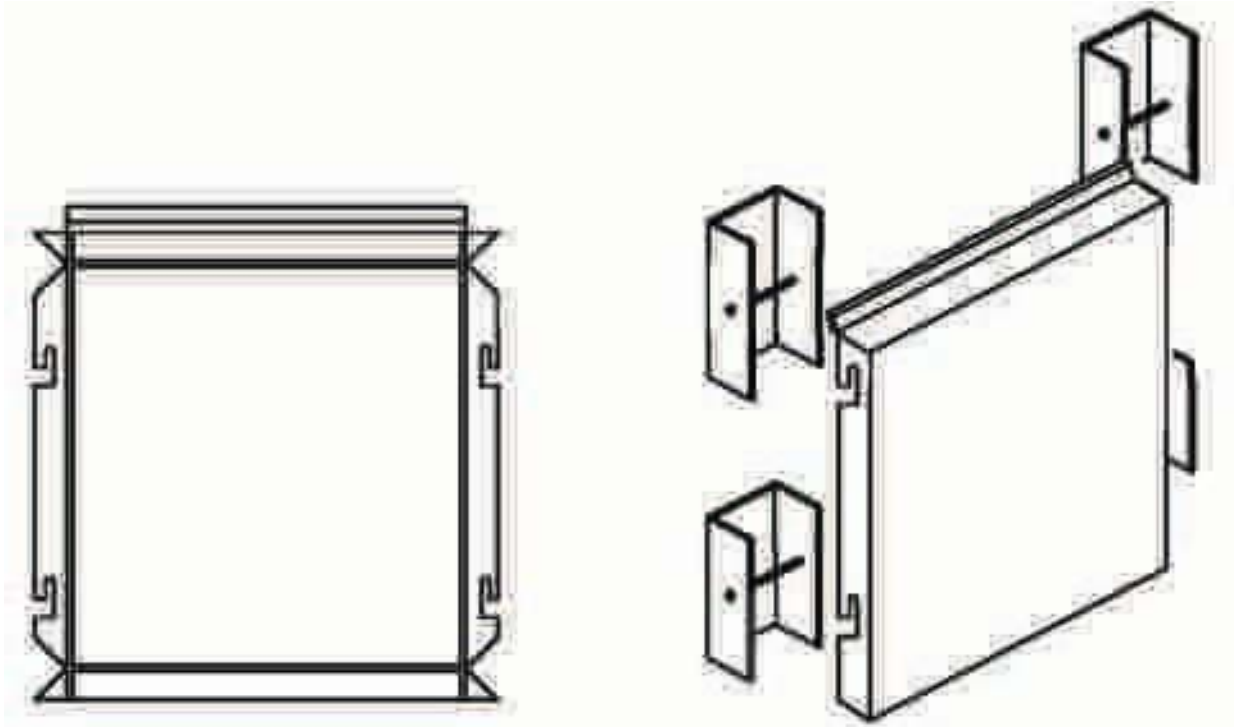

No : 5182
Kompozit Panel Prf.
1,230 kg/m

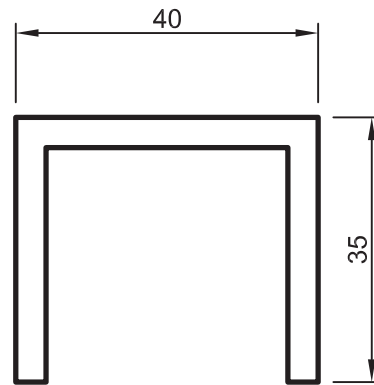

No : 839
U Profili
1,110 kg/m



No : 504
Ø 8 Dolu Çubuk
0,140 kg/m

Uyarı: Profil ağırlıklarımız teorik olup; teslim anındaki tartımız geçerlidir.
Warning: the weights of profile is theoretical, weighting at the time of delivery are valid.

Ölçek: 1 / 1

- Detaylar
- Details

Kompozit Panel Cephe Kaplama Sistemi

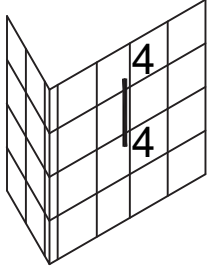

5182
Taşıyıcı Dikme
Hizası

Paslanmaz
Çelik Dübel

U Ankraj

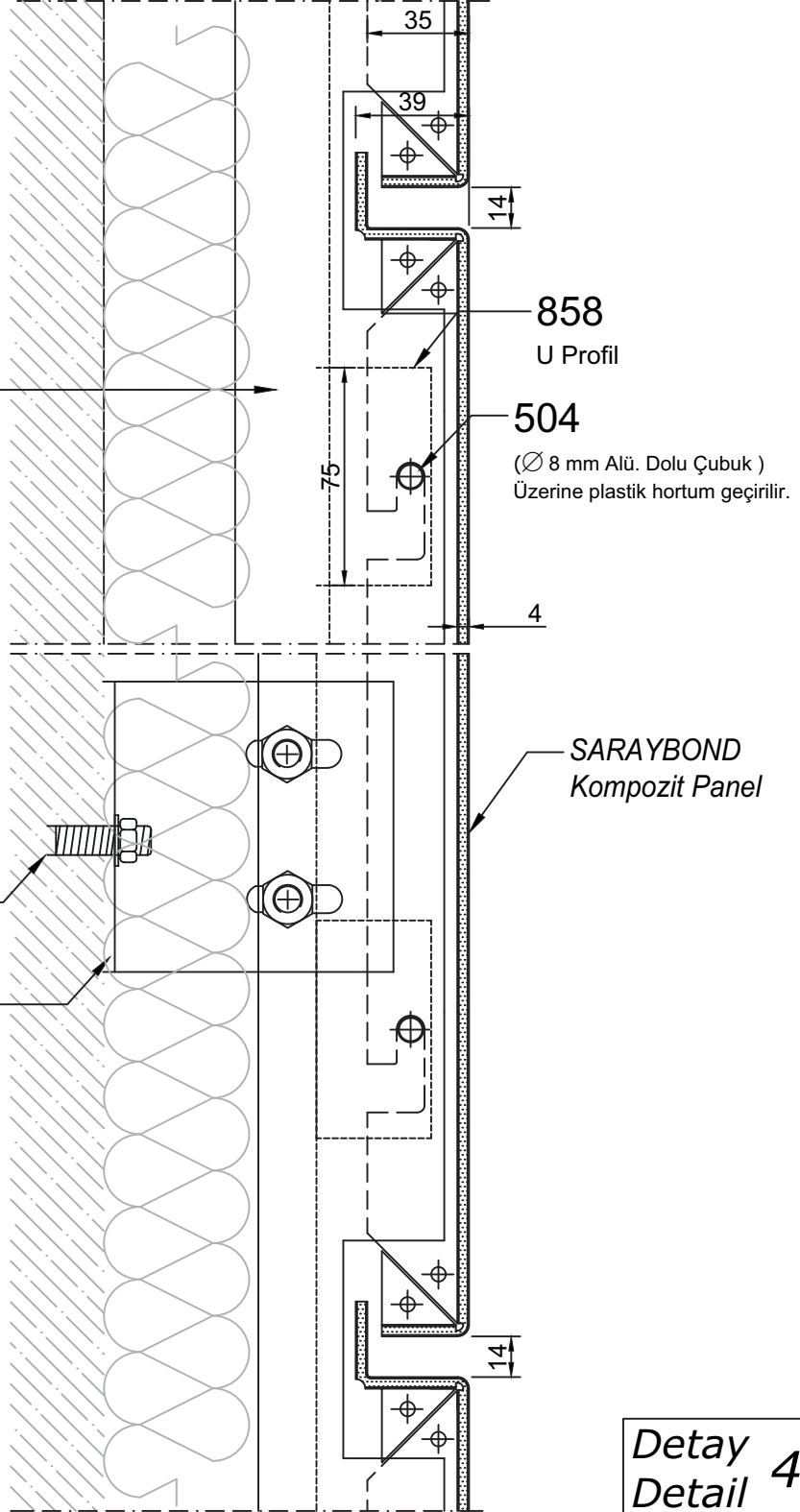

Detay
Detail 4-4

Ölçek:1 / 2.5

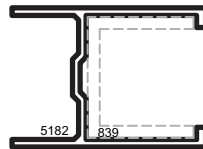

- Detaylar
- Details

Kompozit Panel Cephe Kaplama Sistemi

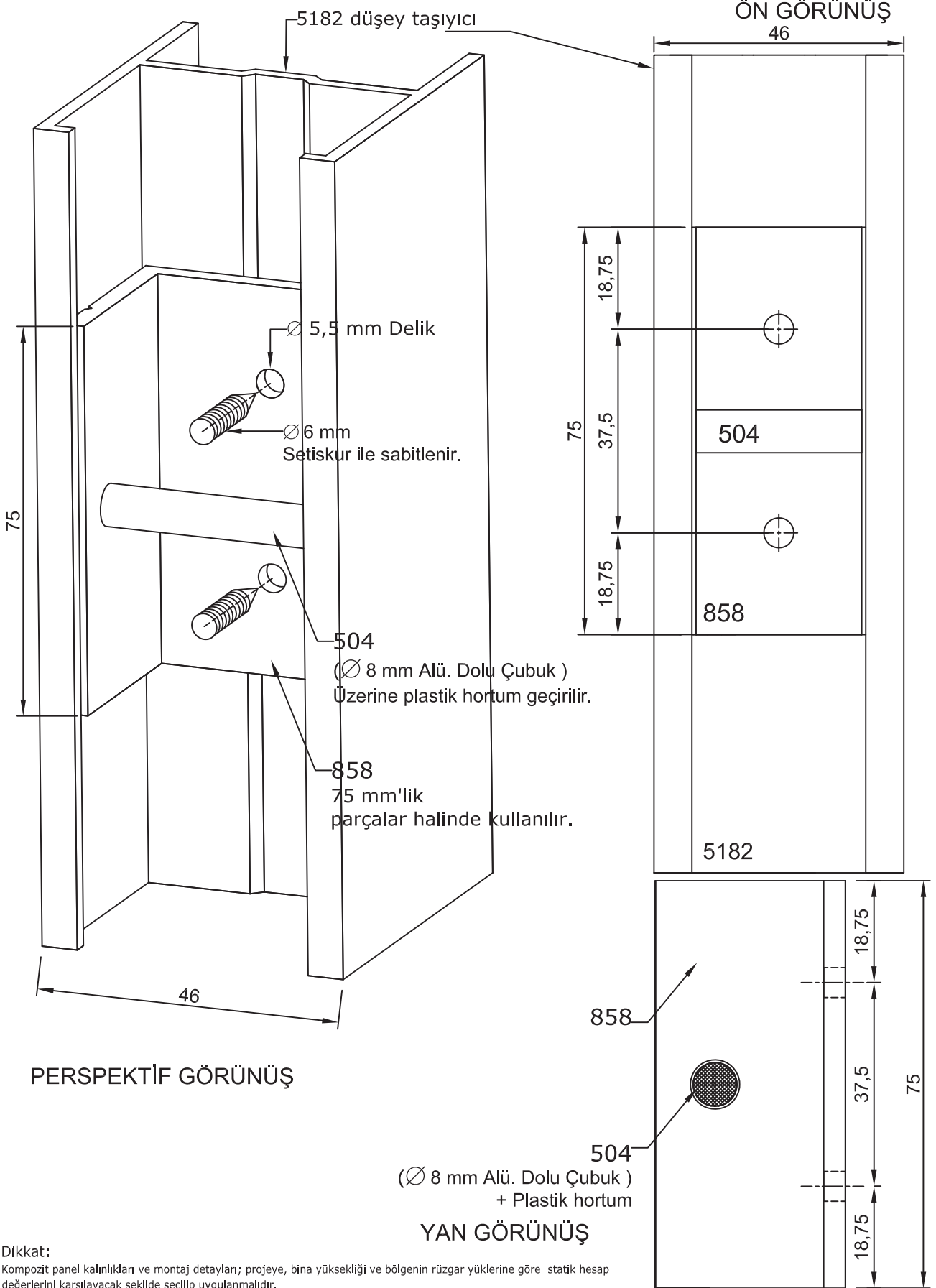

Dikkat:

Kompozit panel kalınlıkları ve montaj detayları; projeye, bina yüksekliği ve bölgenin rüzgar yüklerine göre statik hesap değerlerini karşılayacak şekilde seçilip uygulanmalıdır.

**SARAY KOMPOZİT
SİSTEM 7 DETAYLAR**

***SARAY COMPOSITE
SYSTEMS 7 DETAILS***

- Detaylar
- Details

Kompozit Panel Cephe Kaplama Sistemi

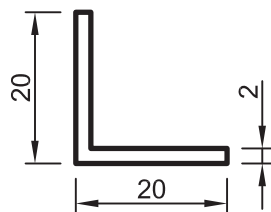
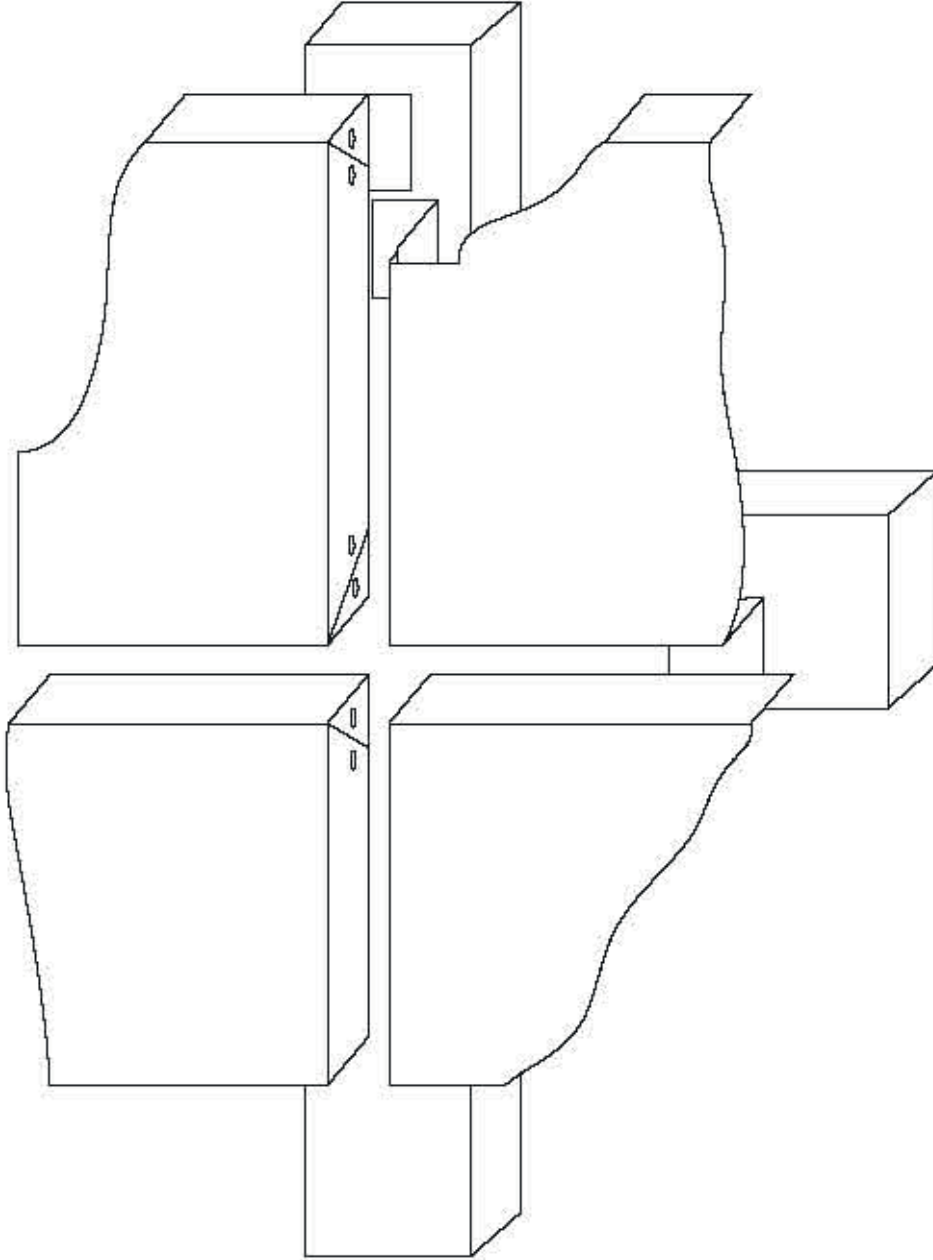

No : 1418

20x20 Köşebent
0,215 kg/m

- Detaylar
- Details

Kompozit Panel Cephe Kaplama Sistemi

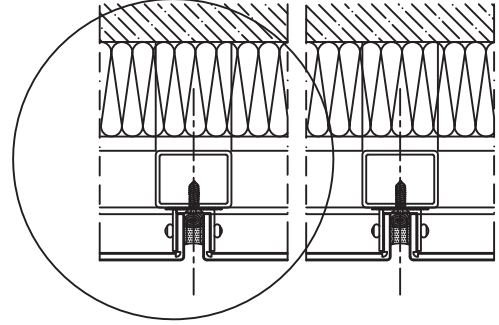
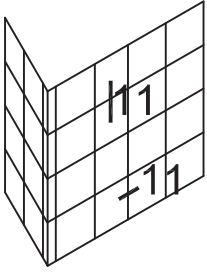

Detay 11
Detail 11

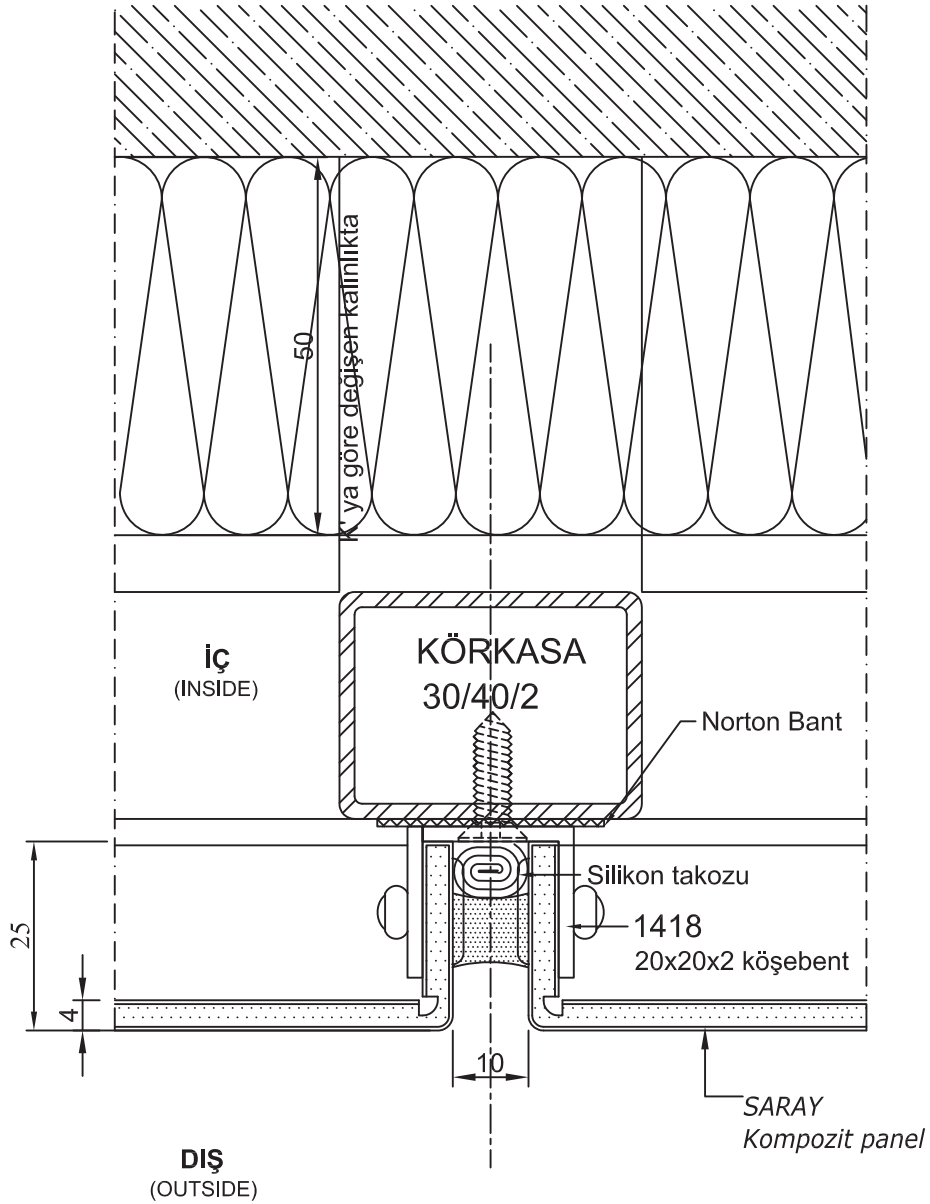

Dikkat:

Kompozit panel kalınlıkları ve montaj detayları; projeye, bina yüksekliği ve bölgenin rüzgar yüklerine göre statik hesap değerlerini karşılayacak şekilde seçilip uygulanmalıdır.

SARAY KOMPOZİT SİSTEM 8 DETAYLAR

*SARAY COMPOSITE
SYSTEMS 8 DETAILS*

- Detaylar
- Details

Kompozit Panel Cephe Kaplama Sistemi

